

**COMMITTEE REPORT: Sign By-law Review Committee**



**MEETING DATE:** December 31, 2013  
**MEETING TIME:** E-mail Discussion Only  
**SUBJECT:** Royal Harbour Resort Sign Variance  
**PREPARED BY:** Sharon Long, Admin. Assistant, Planning & Building Services

**A. Recommendations**

**Recommendation (Move, Second)**

THAT Council refuse a variance to the Town's Sign By-law of Royal Harbour Resort to install a sign at 35 Arthur Street West.

**B. Attachments**

B.1 Copy of the Sign By-law Review Committee minutes.

**C. Public Meetings / Deputations**

N/A

**D. Minutes**

N/A

**E. Correspondence**

N/A

**F. Next Meeting Date**

At The Call of the Chair.

**Minutes: Sign By-law Review Committee**



**MEETING DATE:** December 31, 2013  
**MEETING TIME:** E-mail Discussion Only  
**LOCATION:** Royal Harbour Resort Sign Variance  
**PREPARED BY:** Sharon Long, Admin. Assistant, Planning & Building Services

**A. Call to Order**

Electronic Consideration Only

**B. Request for Sign Variance**

Sign By-law Variance – Reference Application No. PRSV2013-759

Application:

The Sign By-law Variance was applied for by Royal Harbour Resort in December of 2013. Their request was to install a sign on the property located at 35 Arthur Street West directing people to the Royal Harbour Resort.

The Sign By-law Review Committee considered the following variances to the By-law:

Under the Town's Sign By-law 2001-57, a directional sign is described in the By-law as follows:

***Directional Sign – shall mean an on-premise sign giving directions, instructions, or facility information and which may contain the name or logo of an establishment but shall not contain advertising copy, e.g. parking or exit and entrance signs. The area of a Directional Sign shall not exceed 0.5 metres. The logo shall not comprise more than twenty percent (20%) of the total sign area.***

Under the Town's Sign By-law 2001-57, a billboard sign is described in the By-law as follows:

***Billboard Sign – shall mean a sign which advertises goods, products, services or facilities not available at the premises upon which the sign is located or which directs persons to a different location from that upon which the sign is located.***

Under Section 3.01 – Sign Prohibited as the By-law described a prohibited sign as follows:

***The following types of signs are prohibited in all districts:***

**(3) Billboard signs.**

Please also take into consideration when looking at this sign, sight lines along Highway 26.

The following resolution was recommended in the Sign By-law Review Committee minutes dated December 31, 2013:

*Moved by: Ted Decorso                      Seconded by: Michael Martin*  
THAT Council refuse a variance to the Town's Sign By-law of Royal Harbour Resort to install a sign at 35 Arthur Street West, **CARRIED**

Electronic Discussion:

Ted Decorso – I think they should follow the By-law.

Michael Martin – I agree with Ted Decorso's comments.

R. J. Gamble – Declaration of Pecuniary Interest on this application as he is a surrounding property owner.

### **C. Recommendation**

THAT Council refuse a variance to the Town's Sign By-law of Royal Harbour Resort to install a sign at 35 Arthur Street West.

### **D. Attachments**

D.1 Copy of proposed sign to advertise Royal Harbour Resort.

D.2 Copy of the Site Plan.

### **E. Next Meeting**

At the Call of the Chair.

39"

17 3/4"

48"

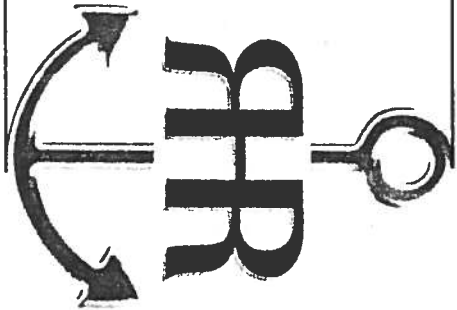

Royal  
Harbour  
Resort

1 Harbour Street, Thornbury

1 3/4"

4 1/4"

RECEIVED

SEP 19 2013

TOWN OF THE BLUE MOUNTAINS  
PLANNING & BUILDING SERVICES  
PER \_\_\_\_\_

Reservations  
1-877-540-8633  
519-599-5591  
Daily & Weekly Rentals and Sales

3"

2"

PARKS, GREG  
PT LOT 29  
35 ARTHUR ST W  
SIGN - ROYAL HARBOUR

PRSG2013-604  
ROLL #17-142-00  
SEPT 19, 2013  
B13-0604

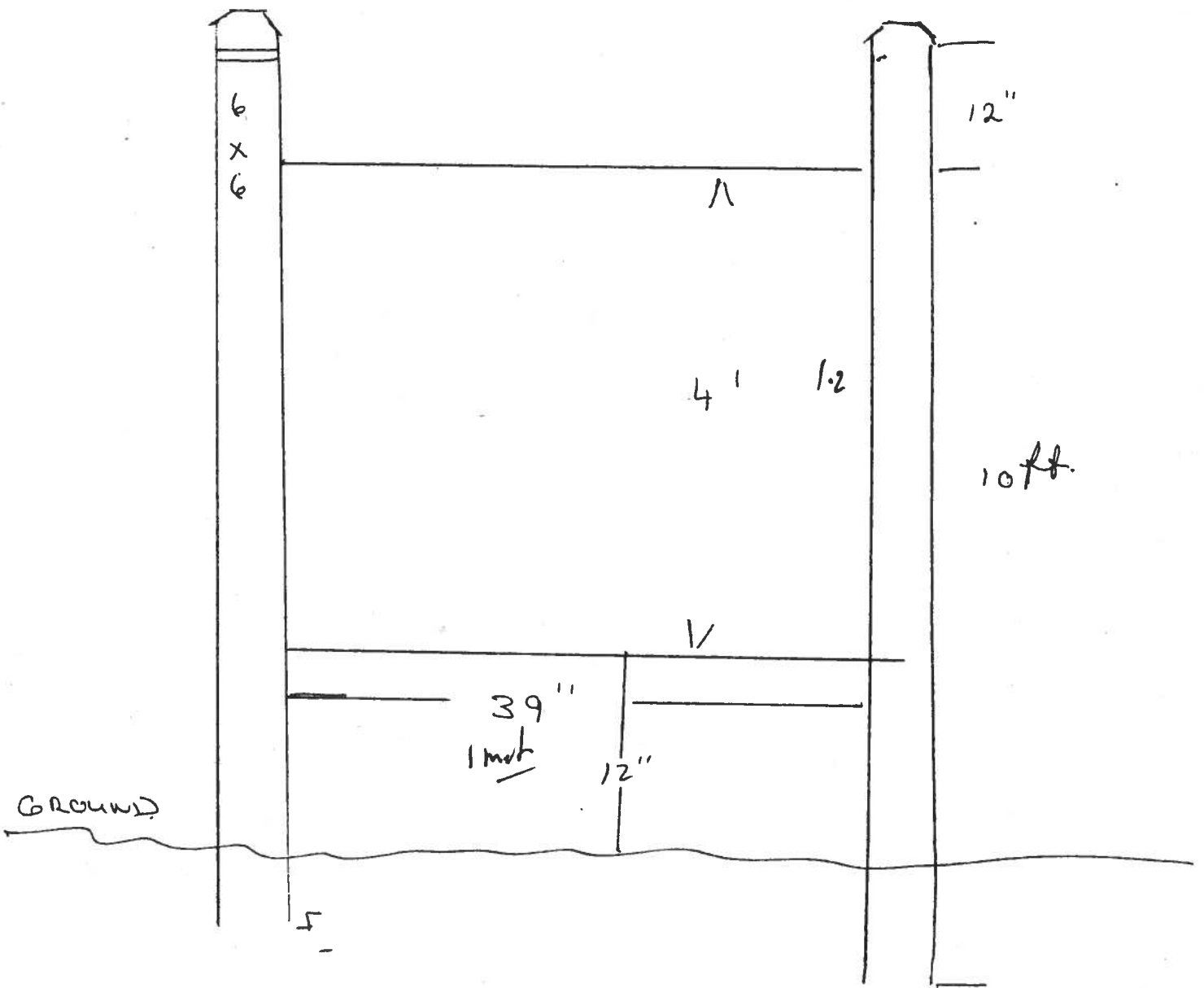

RECEIVED

SEP 19 2013

TOWN OF THE BLUE MOUNTAINS  
 PLANNING & BUILDING SERVICES

PER \_\_\_\_\_

LOCATED 10 FT FROM  
PROPERTY LINE  
5 FT FROM NORTHER ST  
PROPERTY LINE

AS Per General Site  
Physics 5.1  
Ground level = 10'

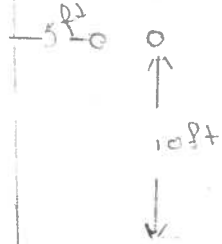

FENCE LINE

SIDE WALK

ARTHUR ST.

ELMA ST.

RECEIVED

SEP 19 2013

TOWN OF THE BLUE MOUNTAINS  
PLANNING & BUILDING SERVICES  
PER \_\_\_\_\_

