

**STAFF REPORT:      Engineering & Public Works Department**

**REPORT TO:** Council  
**MEETING DATE:** October 14, 2009  
**REPORT NO.:** EPW.09.099  
**SUBJECT:** Clarksburg Parking Improvements  
**PREPARED BY:** Jim McCannell, Manager of Roads and Drainage Division

**A. Recommendations**

THAT Council approve increasing the budget for the Clarksburg parking lot improvements by \$11,000.00 from \$62,000.00 to \$73,000.00 for drainage improvements and paving of the parking lot; and

THAT Council approve the additional funds be taken from Road and Drainage operating budget for hot mix paving, account G/L 1-308-3001- 64057; and

THAT Council award the contract for the resurfacing of the Clarksburg Municipal Parking Lot to Harold Sutherland Construction in the amount of \$65,336.00 excluding GST as outlined in EPW report.09.099 entitled "Clarksburg Parking Improvements".

**B. Background**

The Town has been working to improve the municipal parking lot in Clarksburg. The parking lot had the old asphalt surface pulverized, broken up and then mixed in with the gravel. The old stone foundation was also exposed and the top 0.5 m was removed. This has lowered the entrance and makes it easier for cars to enter the parking lot. Most of this work was completed by Town Staff at the cost of \$6,800.00. The time that town Staff worked on project has been applied to the capital budget and not to the operating budget.

Staff have surveyed the site and completed the design for the parking lot. A copy of the site plan is attached. The construction estimate for this work was \$45,000.00. Based on this value a formal request for quotation was issued on September 23, 2009 and closed on October 8, 2009. Two bids were received, the results are shown in the table below:

Company Name	Quotation Prices Submitted ( Excluding GST)
Harold Sutherland Construction	\$65,336.00
Dinsmore Excavating & Haulage Ltd.	\$70,752.50

The capital budget for this project is \$62,000 of which \$6,800 has been expended for a balance of \$55,200. This contract can not be awarded due to the budget shortfall of \$10,136 as outlined in the table below:

Capital budget	62,000.00
Previously expended	6,800.00
Total remaining	\$ 55,200.00
Low bid	\$ 65,336.00
Shortfall	-(10,136.00)

Staff recommends increasing the budget by \$11,000.00. This shortfall can be funded from the hot mix paving operating fund which has a remaining balance of \$32,402.50.

### **C. The Blue Mountains' Strategic Plan**

This tender award furthers the Town's Strategic Goal #2, "Addressing the Town's municipal infrastructure needs".

### **D. Environmental Impacts**

The Contractor will be asked to comply with the Town's anti idling program.

### **E. Budget Impact**

Upon the completing of the paving works on Victoria Street the Roads and Drainage account for Hot mix paving has \$32,402.50 unexpended.

G/L 1-308-3001-64057	\$80,000.00
Victoria St paving	47,597.50
Total remaining	32,402.50

After the Clarksburg Parking Improvement, this account would have a remaining balance of \$32,402.50 – 11,000 = \$21,402.50. It will be proposed as part of year end financing to roll the unexpended amount into 2010 to increase the paving that can be completed next year.

**F. Attached**

Attached : Clarksburg Municipal parking lot site plan.

Respectfully submitted,

---

Jim McCannell  
Manager of Roads and Drainage Division  
Engineering and Public Works  
Office: 519-599-3131 Ext 271  
Fax: 519-599-3664  
[jmccannell@thebluemountains.ca](mailto:jmccannell@thebluemountains.ca)

---

Reg Russwurm  
Director of Engineering and Public Works

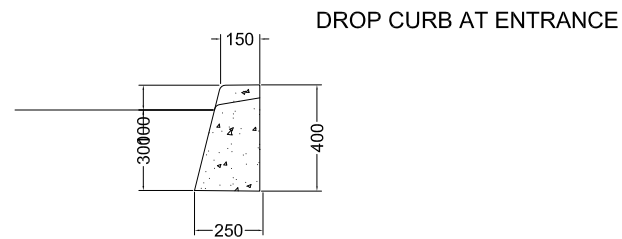

RIBBON CURB - DETAIL A

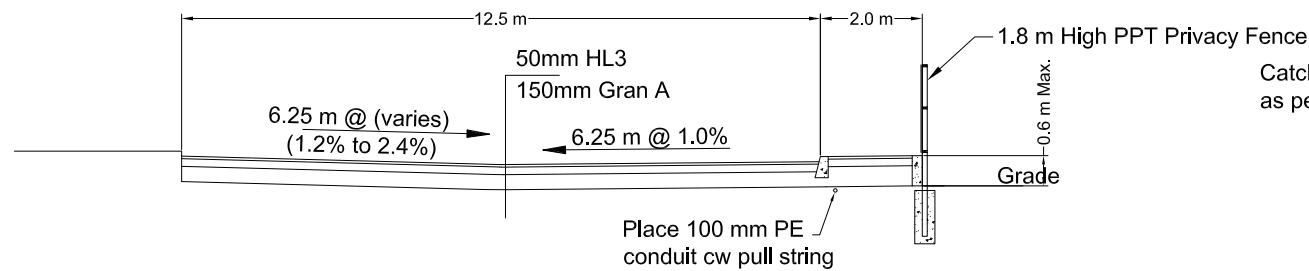

SECTION A-A

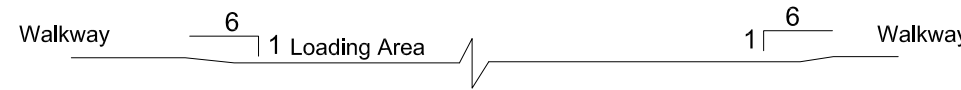

SECTION B-B

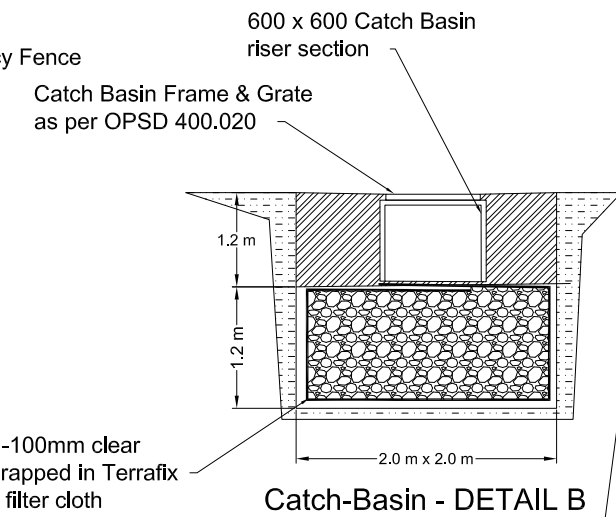

Catch-Basin - DETAIL B

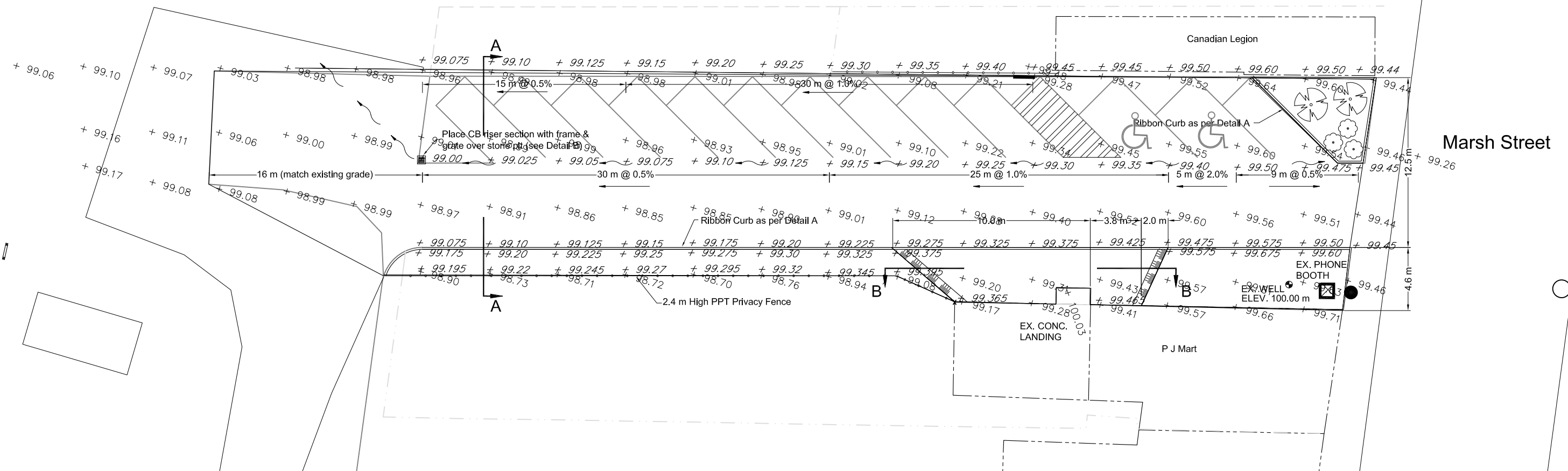

Temporary Bench Mark Elevation 100.00 m. Top of well casing at north/east corner of P J Mart