

STAFF REPORT: **Engineering and Public Works Department**



REPORT TO: **Infrastructure and Recreation
Committee**

MEETING DATE: **March 24, 2009**

REPORT NO.: **EPW.09.028**

SUBJECT: **The Blue Mountains Engineering
Standards - Revised March 2009**

PREPARED BY: **Tom Gray - Engineering Design
Technologist**

A. Recommendations

THAT Council receive Report EPW.09.028 entitled "The Blue Mountains Engineering Standards, Revised March 2009" for their information.

B. Background

The Town endeavours to maintain current best management practices and materials in the design and construction of its infrastructure. The Engineering Standards are intended to inform the developers and consultants as to the process and minimum requirements for developing lands within the municipality and also for reconstruction of Town works.

Through scheduled meetings and e-mails, the Engineering Division requested and received input from Developers and Consultants. The updated Engineering Standards (Attachment #1) attempt to address many of their concerns and implement many of their suggestions. Staff have also reviewed other municipal engineering standards to determine best practices.

Engineering Standards will constantly be reviewed to ensure the standards are current. Staff intends to update and reissue the Standards annually. The Engineering Division will be reviewing the Engineering Standards in greater detail over the next year and will be issuing a comprehensive package for the 2010 construction season.

Key changes implemented in the March 2009 revisions include the submission process, storm water management facilities and deletion of sanitary sewer inspection tees. The Town worked with the developers and consultants to come up with a more logical order for drawing submissions. This will enable the consultant and the Town to agree on specific issues prior to completing design components which affect other consultants and utility companies involved in the project. This is intended to eliminate the need for redesigning from all parties. The most significant change to the submission process is including a 6 month time limit from issuing Accepted for Construction (AFC) drawings to entering into

an Agreement. After this time limit, the drawings are not longer considered AFC and the Developer will be required to re-submit the drawings for approval at the discretion of the Town.

The Town has also introduced optional design criteria for storm water management facilities which incorporate flatter slopes around storm ponds in place of installing chain link fencing. The ponds can be landscaped to resemble a natural wetland.

Another significant change has been the elimination of the sanitary inspection tees. They have been removed from the Engineering Standards as they have been identified as having a major infiltration potential to the sanitary collection system.

The Standards have also included new design criteria for cul-de-sacs and P-Loop roads one of which is limiting the number of dwelling permitted on each before a secondary (emergency) access is required to ensure residents and emergency vehicles have access if the primary road is impassable.

The Town has also attempted to clarify ambiguous sections of the standards that it feels the consultants have misinterpreted in the past.

C. The Blue Mountains' Strategic Plan

The revised Engineering Standards furthers the Town's Strategic Goal #2 "Addressing the Town's Municipal Infrastructure Needs" and Goal #6 "Providing a strong well managed municipal government".

D. Environmental Impacts

The Engineering Standards set design standards to ensure impacts to the natural environment are minimized. With clear and concise Engineering Standards, there should be a reduction in the number of re-submissions of each drawing package. This would bring about a significant reduction in paper wastage.

E. Budget Impact

It is intended to standardize and subsequently streamline the development process and in effect reducing the number of hours involved in reviewing and editing development submissions through the Technical Review process.

F. Attached

1. The Blue Mountains Engineering Standards, Revised March 2009

Respectfully submitted,

Tom Gray
Engineering Design Technologist

Reg Russwurm
Director, Engineering & Public Works
Department

For more information, please contact:

Name Tom Gray
Email Address: tgray@thebluemountains.ca
Business Telephone with Extension : (519)599-3131 ext 277



The Blue Mountains Engineering Standards

Revised March 2009

Intentionally left blank

The Blue Mountains Engineering Standards

Contents

1	GENERAL REQUIREMENTS	5
1.1	Introduction	5
1.2	Definitions	5
2	DEVELOPMENT DESIGN SUBMISSIONS	6
2.1	Introduction	6
2.2	Submissions to Government Agencies	6
2.3	First Submission to the Town	7
2.4	Second Submission to the Town	9
2.5	Third Submission to the Town (if required)	10
2.6	Final Submission to the Town	10
2.7	Expiration of “AFC” drawings	11
2.8	Pre-Servicing Policy for Subdivision Development	11
3	DRAWINGS	12
3.1	Specifications for Engineering Drawings:	12
3.2	General Drawing Requirements	12
3.3	Computer Aided Drawings (CAD)	13
3.4	General Plans	13
3.5	Record Drawings	20
4	DESIGN AND CONSTRUCTION REQUIREMENTS	22
4.1	Introduction	22
4.2	Storm Water Management System	22
4.3	Sanitary Sewer System	42
4.4	Water Supply System	48
4.5	Roadways	55
4.6	Street Name and Traffic Signs	62
4.7	Roadway Markings	62
4.8	Traffic Signals	63
4.9	Street/Site Lighting	63
4.10	Residential Lot Drainage And Sodding	64
4.11	Block Grading	65
4.12	Erosion and Sediment Control	66
4.13	Utilities	67
4.14	Canada Post	67
4.15	Landscaping	67
5	GEOTECHNICAL	68
5.1	Geotechnical Report	68
5.2	Geotechnical Engineering Inspection	69
6	TOWN GARBAGE/RECYCLING COLLECTION	70

LIST OF DRAWINGS

Drawing RD-STD-U1	Standard Cross-Section 8.5m Road - 20m ROW71
Drawing RD-STD-R2	Rural Standard Cross-Section 9.0m Road - 20m ROW72
Drawing ST-STD-01	Owen Sound Intensity Duration Frequency (IDF) Curve73
Drawing SW-STD-01	Solid Waste Enclosure for Multi Units Residential (plan)74
Drawing SW-STD-02	Solid Waste Enclosure for Multi Units Residential (section)75
Drawing LT-STD-A-FIXTURE	Street Lighting Fixture Style A76
Drawing LT-STD-B-FIXTURE	Street Lighting Fixture Style B77
Drawing LT-STD-A-POLE	Street Lighting Pole Style A78
Drawing LT-STD-B-POLE	Street Lighting Pole Style A79
Drawing ST-STD-SUMP	Residential Storm Sewer Connection (100mm)80

1 GENERAL REQUIREMENTS

1.1 Introduction

The Blue Mountains Engineering Standards presented here are intended as the Town's requirements to aid in the uniform design and installation of infrastructure throughout the Municipality. Innovative technological changes that improve or maintain the quality of the Works on a life cycle cost basis may be considered at the discretion of the Town.

These standards are to be read in conjunction with the Ontario Provincial Standard Specifications (OPSS) and the Ontario Provincial Standard Drawings (OPSD).

It is the Designer's responsibility to obtain and check with The Blue Mountains for the latest version. Copies are available on the Town's website at www.thebluemountains.ca

The Town reserves the right to make project specific requests deemed reasonable by the Town Engineer.

1.2 Definitions

In this specification the following definitions shall apply:

"AFC" shall mean Accepted For Construction

"AWWA" shall mean the American Water Works Association.

"CHBDC" shall mean the Canadian Highway Bridge Design Code.

"Consultant Engineer" shall mean professional engineers licensed to practice in Ontario and shall be responsible for the preparation of drawings and specifications to the satisfaction of the Town's Engineer. "Engineer" and "Designer" shall mean the same as Consultant.

"Contractor(s)" shall mean the firm of Contractors, the company or individual acting as the Contractor and having entered into a contract with the Developer/Owner to install the services.

"Developer(s)/Owner(s)" shall mean the person(s) causing the Works to be undertaken.

"DFO" shall mean the Department of Fisheries and Oceans, Canada.

"GSCA" shall mean the Grey Sauble Conservation Authority.

"MNR" shall mean the Ontario Ministry of Natural Resources.

"MOE" shall mean the Ontario Ministry of the Environment.

"MTO" shall mean the Ontario Ministry of Transportation.

"NEC" shall mean the Niagara Escarpment Commission.

"NVCA" shall mean the Nottawasaga Valley Conservation Authority.

"OBC" shall mean the Ontario Building Code.

"OPSD" shall mean the Ontario Provincial Standard Drawings.

"OPSS" shall mean the Ontario Provincial Standard Specification.

"Town" shall mean The Blue Mountains.

"Town Engineer" shall mean the Director of Engineering and Public Works of the Town of The Blue Mountains or designate.

"Town Representative" shall mean any person assigned to a project by the Town to carry out work on their behalf.

2 DEVELOPMENT DESIGN SUBMISSIONS

2.1 Introduction

This section outlines the required submissions to be made to the Town in regards to development projects.

The submission of all reports and drawings are to be coordinated by the owner's Consultant. The submission requirements for Town initiated projects shall be coordinated between the Town and the Consultant.

Prints of drawings for all submissions shall be in accordance with Town standards and each print shall be stamped with the submission number (1,2, or 3) and date of submission.

2.2 Submissions to Government Agencies

The Consultant shall deal directly with the Ministry of the Environment (MOE), Ministry of Natural Resources (MNR), Ministry of Transportation (MTO), Niagara Escarpment Commission (NEC), Nottawasaga Valley Conservation Authority (NVCA) or Grey Sauble Conservation Authority (GSCA), as applicable, Department of Fisheries and Oceans (DFO), Grey County and any other government agencies for works that fall within their jurisdiction. It is the responsibility of the Consultant to ensure that all correspondence, comments and approvals are provided to the Town.

2.3 First Submission to the Town

The following submissions shall be compiled and submitted in their entirety by the owner's Consultant in one complete package to the Town. Any incomplete submissions or submission quality deemed to be unacceptable for review by the Town Engineer, shall be returned un-reviewed.

2.3.1 Engineering Submission

- A Letter of Retainer from the Consulting Engineer stating that they have been engaged for the design and general construction inspection of all works, and coordination of sub-consultants.
- One copy of proposed Registered Plan or Site Plan
- Five complete bound sets and 2 bond sets on 11x17 of the following drawings are to be submitted in the following order:
 - Cover Sheet
 - General Servicing Plan
 - Grading Plan(s)
 - Storm Drainage Plan(s)
 - Sanitary Drainage Plan(s)
 - Water Distribution Plan(s)
 - Plan and Profile Drawing(s)
 - Stormwater Management Facilities Drawing(s)
 - Miscellaneous and special detail drawings
- One bound set of drawings containing the following:
 - General Servicing Plan
 - Sanitary Drainage Plan(s)
 - Plan and Profile Drawing(s)
- One bound set of drawings containing the following:
 - General Servicing Plan
 - Water Distribution Plan(s)
 - Plan and Profile Drawing(s)
- Four additional copies of the General Servicing Plan
- Three copies of water supply and distribution report providing calculations to support the design of the distribution works including main sizes, fire flows and

anticipated flows and pressures for domestic and other users.

- Three copies of the Storm Water Management Report and O&M manuals as requested.
- Three copies of the storm sewer calculations on standard design sheets.
- Three copies of sanitary design calculations on standard design sheets.
- Three copies of the Traffic Impact Study (if required)
- Four copies of the Geotechnical Report
- A letter from the Consultant, summarizing the contents of the submission and certifying that the design has been reviewed by a senior engineer and conforms with the Town's Engineering Standards.

2.3.2 Municipal Structures Submission

By definition, a municipal structure is any structure with a clear or adjacent span totalling more than 3.0 metres.

When a new municipal structure is proposed, a specific submission related to the structure is required, which includes the following information.

- Three copies of the General Arrangement drawing(s), prepared in general accordance with the MTO Structural Manual. It includes the roadway structure plan, profile, elevation and cross sections.
- Three copies of the Design Report which includes but is not limited to the description of the works, how the detail was arrived at, different options and cost analysis/least expensive alternate.
- Three copies of the Design Criteria Sheet which includes, but is not limited to, the type/class of roadway, volume of traffic, geometric information and cost estimate.
- Three copies of the Hydrology Report.
- A letter from the Engineer responsible for the design which certifies that:
 - the bridge type, length and width are appropriate;
 - CHBDC requirements are met;
 - Ministry standards have been followed;
 - the most economical life cycle cost solution has been selected for the site,

- The structural design drawings and details included as part of the Subdivision Agreement shall be stamped and signed by the Engineer who designed the roadway structure and by the professional engineer who checked the structural design drawings.

2.4 Second Submission to the Town

The following plans and documents shall be compiled and submitted in their entirety by the Consultant in one complete package. Any incomplete submissions, delivered to the Town, shall be returned.

- Five complete sets of the following drawings are to be submitted and are to be presented in the following order:
 - Revised set of all drawings listed in “First Submission” plus
 - Regulatory Signage Plan(s)
 - Composite Utility Plan(s)
 - Erosion and Sediment Control Plan(s)
 - Detail drawings for outlets and watercourse improvements
 - Landscaping Plan(s)
- Three revised copies of water supply and distribution report if any changes were required.
- Three revised copies of the Storm Water Management Report if any changes were required.
- Three revised copies of the storm sewer calculations if any changes were required.
- Three revised copies of sanitary design calculations if any changes were required.
- Three copies of the Traffic Impact Study if any changes were required.
- Three copies of photometric design calculations.
- Three copies of the Acoustical Report (if required).
- Three copies of the Arborist Report (if required).
- One set of Landscape Drawings additional to bound set above.
- A Letter of Retainer from the Consulting Landscape Architect stating that they have been engaged for the design and complete general construction inspection of all landscape works, plus an outline of the items contained within the submission.

- A covering letter from the Consulting Engineer stating that the landscape work is in conformity with the proposed grading and municipal services for the development, plus an outline of the items contained within the submission.
- A letter from the Consultant, summarizing the contents of the submission and certifying that the design has been reviewed by a senior engineer and conforms with the Town's Engineering Standards.

2.5 Third Submission to the Town (if required)

Same as second submission

2.6 Final Submission to the Town

After final approval by the Town of the aforementioned submissions, the following is required:

- One copy of the Proposed Registered Plan or Site Plan.
- Five complete 'full size' sets and two complete 'reduced' (11x17) sets of all drawings to be approved.
- All drawings must be stamped and signed by the Consulting Engineer or Landscape Architect as appropriate.
- A digital copy in "dwg" format of the complete set of engineering drawings in accordance with the Town drawing requirements.
- Three reduced copies (11x17) of the final storm drainage plan and the storm sewer design sheet labelled final design.
- Three reduced copies (11x17) of the final sanitary drainage plan and the sanitary sewer design sheet labelled final design.
- Copies of all required agency approvals - i.e. GSCA, MOE, NEC, NVCA, etc.
- Detail cost breakdown of all proposed works in MS Excel format.
- Evidence in writing that agreements are in place with Bell Canada, Cable TV, and Hydro for the installation of these utilities in a common trench in the prescribed locations on road allowances within the plan of subdivision.
- Evidence in writing that an agreement is in place with Union Gas for the installation of their utility in the prescribed location on road allowances within the plan of

subdivision.

- Evidence in writing that satisfactory arrangements are in place with Canada Post for the location of mailboxes.

Two sets of drawings stamped “Accepted For Construction” (AFC) will be returned to the Consultant. Only drawings stamped “Accepted For Construction” in red ink, shall be considered originals for the purpose of interpretation of the required Works. Any field changes or post AFC modifications to the drawing originals by the Consultant must be approved and stamped “AFC” by the Town prior to construction.

2.7 Expiration of “AFC” drawings

The “AFC” drawings will be valid for 6 months after Town approval unless a Development Agreement is executed.

If a Development Agreement has not been entered into within the 6 month period, the “AFC” designation must be re-issued. It will be at the Towns discretion to review the drawings prior to re-issuing “AFC”.

2.8 Pre-Servicing Policy for Subdivision Development

Subsequent to Draft Plan Approval and prior to execution of a Subdivision Agreement, the Town may consider Pre-Servicing of a development at the owner's risk when the following conditions have been met:

- The Developer must execute a Pre-Servicing agreement and deposit required securities with the Town or execute and deposit the requisite agreement fees and securities with the Town.
- Engineering drawings have been “Accepted for Construction Pre-Servicing Only” for the Works under consideration. The drawings shall be prepared in a manner to clearly distinguish the Pre-Servicing Works. Only drawings stamped “Accepted for Construction Pre-Servicing Only” in red ink, shall be considered originals for the purpose of interpretation of the required Works.
- Written approval of various agencies, e.g., GSCA, MOE, NEC, NVCA, MNR, MTO, Ministry of Citizenship, Culture and Recreation, where they relate to the installation of services permitted by the Pre-Servicing Agreement.
- Written confirmation from utility companies that satisfactory agreements have been reached for provision of respective services.
- Permission will not be given to construct external services prior to execution of the Subdivision Agreement. Connections to existing municipal services will not be

permitted until the plan is registered. Only one gravelled access to the public road system will be granted.

- All other documents considered necessary to the Works under the Pre-servicing Agreement including, 300 mm reserves, easements, etc., must be approved as to form and description as described in the Pre-servicing Agreement.
- Above ground works will not be permitted to commence unless approved in writing by the Town.
- If applicable, a servicing permit pursuant to the Building Code Act has been obtained.

3 DRAWINGS

3.1 Specifications for Engineering Drawings:

3.1.1 Size

Drawings to be Metric Standard A1 (566mm X 801 mm) or Imp. Equivalent (24" X 36")
Reduced drawings on Metric Standard A3 (280mm X 240mm) or Imp. Equivalent (11" X 17")

3.1.2 Materials for all Submission and "Record" drawings

- Bond (Paper)
- Translucent Mylar for "Record" drawings (0.04mm matte)
- Black Ink (permanent)
- Digital copies on CD in AutoCad version 2004 or later

3.2 General Drawing Requirements

All drafting work on the drawings to be done neatly and legibly. The following basic information and criteria shall apply in preparation of the drawings:

- all plans shall include a north arrow and Key Plan in the upper right hand quadrant
- all text to be horizontal, vertical read from right side of page, or aligned to feature described (eg. pipe)
- all text shall be presented neatly in an orderly manner and not over lapping
- text size for general notes and descriptions shall be 2.0mm plotted size (Leroy 80)
- text size shall not be less than 1.5mm plotted size (Leroy 60)
- text size for headings and titles to be appropriate for use
- drawings shall be signed and sealed by the Professional responsible for the design
- elevations are to be geodetic and related to the Geodetic Survey of Canada datum
- a local benchmark note shall appear in each drawing

- rubber stamps shall not be used except for the Professional's seal
- nothing shall be affixed to the drawing with tape or adhesive
- the drawings shall indicate the submission phase to which they apply
- existing information shall be shown light or background line weight
- proposed information shall be shown bold or foreground line weight
- in general, east-west streets shall have zero chainage at their westerly limit and north-south streets shall have their zero chainage at their southerly limits.
- chainage on a plan-profile shall increase from left to right.
- Key Plan drawn at 1:10,000 scale shall be shown in all plan and profile drawings and any other plans that encompass more than one drawing sheet, with the area covered by the drawing clearly identified.
- legend is to be provided on each drawing or a comprehensive legend on second sheet.
- Cross reference number scheme for each section or detail.

3.3 Computer Aided Drawings (CAD)

All drawings shall be prepared using AutoCAD, version 2004 or later.

3.4 General Plans

3.4.1 Cover Sheet

The Cover Sheet shall contain a Key Plan which clearly identifies the location of the proposed project. Provide the name of the project, the municipality, consultant and a drawing index (optional on page 2).

3.4.2 General Servicing Plans

General plans showing aboveground services and appurtenances are to be drawn to a scale of 1:1000. When more than one "General Servicing Plan" is required, a supplementary "General Servicing Plan" at a smaller scale shall be prepared to show the entire plan of development on one drawing.

The General Servicing Plan shall show but not be limited to:

- road allowances, lots, blocks, easements, daylighting and reserves in the same manner as shown on the registered plan;
- watermains and appurtenances, with notes showing sizes;
- maintenance hole numbers;
- sewers with notes showing flow type, size, and direction of flow;
- lot numbers per registered plan with provision to add street addresses when available;
- future land use identified;
- retaining walls;
- rear lot/block catchbasins;

- community mail boxes;
- hydro vaults, street lights, sidewalks;
- existing watercourse across lands or adjacent to lands:
- existing land use bordering lands extended far enough to clearly identify adjoining roads, buildings, driveways, utilities poles, hydrants, sewers and ditches:
- fill and flood line restrictions as specified by the local Conservation Authority
- clearly identify phasing and/or staging of the works
- clearly identify lands to be conveyed to the Town

3.4.3 Grading Plans

Grading plans are to be drawn to a scale of 1 to 500 and shall clearly provide sufficient information to fully understand the movement of stormwater.

The grading plans shall indicate, but not be limited to, the following:

- existing 1.0 metre contours extended outside the subject lands far enough to determine the existing drainage pattern. If land is relatively flat, reduce to 0.5m contour intervals;
- on steeper grades, label only even numbered contours;
- driveway locations and building envelopes if known;
- elevations at existing trees, structures, watercourses, etc.;
- existing and proposed roads with elevations at 20m intervals;
- proposed sidewalks and trails with surface treatment labelled;
- proposed catch-basin's and ditch inlets;
- proposed elevations at front and rear building envelope as per zoning by-law;
- proposed elevations at the corners of each lot and block;
- proposed elevations at side-yard highpoints if applicable;
- proposed elevation at changes in slope
- proposed 0.5m contours for grading within large blocks and parks (> 1.0 ha);
- proposed grades for major and minor overland flow routes;
- lot fabric of subject lands including lot, block and easement description;
- physical structures such as fencing, retaining walls, etc.;
- proposed top of foundation elevation or finished floor (FF) elevation;
- proposed grades for storm system to intercept block and external drainage;
- swale and ditch cross section(s) identifying width, depth, side slope easement or property limits and maximum depth of water;
- proposed grading direction arrows;
- proposed culverts for road crossings;
- proposed overland flow route for major storm events and if it is marginal that major storm events will be contained within road allowance, or requested by the Town, provide high water level for major storm events

3.4.4 Storm Drainage Plans

Storm drainage plans are to be drawn to a scale of 1 to 1000 (a scale not exceeding 1 to 5000 will be accepted for large external drainage areas) and are to indicate the total area to be drained by the proposed storm sewers and drainage system.

The storm drainage plan shall indicate but not be limited to, the following:

- existing 1.0 metre contours with even numbered contours labelled;
- drainage patterns of adjacent lands;
- runoff coefficients and areas (ha) of tributary areas outside the development and for each section of the storm sewers within the development;
- direction of runoff;
- street, blocks, lots and easements;
- street names;
- storm maintenance holes, numbered consecutively from the outlet;
- storm sewer sizes, slope and directions of flow;
- any catchbasins or swales, on the lots or blocks, required to collect the runoff;
- temporary or permanent quantity and quality storm water management facilities;
- major and minor overland flow routes;
- show storm discharge from site to nearest significant watercourse;
- culverts and other drainage appurtenances;
- legend

3.4.5 Sanitary Drainage Plans

Sanitary drainage plans are to be drawn to a scale of 1 to 1000 and are to indicate the total area to be collected by the proposed sanitary sewers.

The sanitary drainage plan shall indicate but, not be limited to, the following:

- sanitary catchment areas (ha) and population per unit for each section of the sanitary sewers within the development;
- overall sanitary catchment area (ha) and population based on population per unit for each upstream section of the sanitary sewer entering the development;
- street, blocks, lots and easements;
- street names;
- sanitary maintenance hole numbers;
- sanitary sewer sizes, slope and directions of flow;
- forcemains
- pump stations
- lot services
- legend

3.4.6 Water Distribution Plan

Water Distribution plans are to be drawn to a scale of 1 to 1000.

The water distribution plan shall indicate but, not be limited to, the following:

- street, blocks, lots and easements;
- street names;
- watermain size and material
- valves
- hydrants
- pump stations
- flushing points
- sample stations
- lot services
- legend

3.4.7 Plan-Profile Drawings

Plan-profile drawings are to be drawn to a horizontal scale of 1 to 500 and a vertical scale of 1 to 50 and are to conform to the following:

- where multiple drawings are required for one street, match lines must be used and there shall be no overlap or duplication of information;
- where intersecting streets or easements are shown on a plan-profile, only the diameter of the pipe and direction of flow of the intersecting sewers shall be shown;
- on profile portion of drawings the type of sewer, material, diameter, length, grade and class of pipe shall be shown;
- on profile portion of drawings the watermain diameter, length, material and class of pipe shall be shown;
- only the type and diameter of pipe shall be shown in the plan portion;
- where possibility of conflict with other services exist, connections are to be plotted on the profile or a crossings chart included;
- provide centre line road elevations at 20.0 m intervals;
- pavement/road base grades for the particular roadway are to be indicated on all plan-profile drawings;
- top of bedrock from all borehole logs is to be plotted on the profile drawings;
- ground water elevation from geotechnical report to be plotted on profile drawings;
- gutter elevation details (% grade) for turning radii, cul-de-sacs and intersections to be shown on the plan;
- provide curb radii at all intersections, cul-de-sac's and horizontal curves
- All existing or future services, utilities and abutting properties shall be shown in dashed or screened line work;
- provide elevation and stationing for BVC, Apex (low point) and EVC on all vertical curves;
- pipe invert and related information shall be shown on the feature described and not

to be presented in table form;

3.4.8 Regulatory Signage Plan

Left blank for now.

3.4.9 Composite Utility Plan

The Composite Utility Plan shall show all the above ground requirements of the General Servicing Plans as well as the proposed location of Bell, Hydro, Gas and Cable TV. All running line and road crossing locations must be established and resolved by the Consulting Engineer in conjunction with the Utility companies and in accordance with the locations shown on the typical cross-section.

3.4.10 Erosion and Sediment Control Plans

Erosion and sediment control plans are to be prepared in accordance with the appropriate Provincial and Conservation Authority Standards.

3.4.11 Details

Provide sufficient details to all works necessary to ensure that there are clear instructions on what is to be built with no ambiguity.

3.4.12 Details for Stormwater outlets and watercourse improvements (if required)

Left blank for now.

3.4.13 Landscaping Plans

3.4.13.1 General

All landscape plans shall be drawn and stamped by a Full Member of the Ontario Association of Landscape Architects. All landscape plans shall be drawn at a minimum scale of 1:500.

The landscape drawings may include the following:

- Existing Natural Features Assessment;
- Tree Survey/Vegetation Analysis;
- Tree Preservation Plan and Details;
- Streetscape and Buffer Planting Plans and Details;
- Detailed Park Development Plans and Details;
- Trails Master Plans and Details;
- Landscape Restoration Plans and Details;

- Stormwater Management Pond Planting Plan.

Construction details will be required for all landscape elements to be implemented as part of the development.

Any required landscape Restoration Plans and Stormwater Management Facility Planting Plans will require both the Town and the appropriate Conservation Authority's approval prior to implementation of the plans.

3.4.13.2 Streetscape Plan

The Streetscape Plan shall show the following:

- all existing trees and natural features to remain with protection details;
- all building envelopes, driveways and sidewalks;
- all walkways, trails and easements;
- all required fencing including privacy, acoustic and chain link;
- all proposed plantings;
- all entry features;
- location of street lighting, public utility boxes, hydrants and other street furniture;
- location of easements

3.4.13.3 Park Development

Detailed Park Development Plans are to be submitted by the Landscape Architect. A complete set of detailed design plans and working drawings are required. Park plans are to be submitted at a scale of 1:500 and shall indicate, but not be limited to, the following:

- existing contours;
- drainage structures and direction of overland drainage;
- species and size of existing plant material to remain and be protected;
- species and size of plant material to be removed;
- layout of all proposed recreation facilities;
- layout of parking lot and spaces (including handicapped parking);
- layout of all trails;
- proposed site amenities including benches, bike racks, trash receptacles, signs;
- perimeter fencing;
- park lighting;
- all surface treatments;
- all proposed plant materials

3.4.13.4 Trails

The Developer may be required to design and construct a trail system, pathways and linkages to existing trail systems which will be identified through the planning process. Pathways adjacent to parkland and walkway easements adjoining parallel roads or acting as service access shall be fenced, gated, and planted according to the Town's Trail Design and Management Planning

Handbook, available from the Town's Recreational Department. The provision of new trails shall be consistent with, and support the existing Town-wide trails network. The trail system in the Town consists of a comprehensive trails network that includes the regional Georgian Trail and a series of multi-use community wide trails.

The Town's trails network is generally comprised of:

- Multi-use urban hard surface trails, 3.0m width (hard surface, multi-use trails)
 - These are used for high-use trails, which can accommodate the widest variety and volume of non-motorized vehicles and users. These trails serve as part of an alternate transportation system for the Town and should be designed for both recreation and transportation. Usage can be year round or seasonal.
- Multi-use urban soft surface trails, 3.0m width (crusher fines, multi-use trails)
 - These are suited for trails with moderate use in urban, suburban, and easily accessed undeveloped areas but where multiple use is not a priority. Soft surface trails are typically not maintained during winter months, but does not preclude winter usage
- Multi-use rural soft surface trails, 2.0m width (crusher fines, multi-use trails).
 - These are suited for trails with moderate use in rural areas but where multiple use is not a priority. Soft surface trails are typically not maintained during winter months, but does not preclude winter usage.
- Natural surface trails, 2.0m width (natural surface, multi-use trails)
 - These are suitable for low to moderate use country and backcountry hiking trails where a natural and undeveloped feel is desired. Trail width can vary to handle the expected volume and types of use.
- Road based cycle routes, 1.0m width and safety buffer
 - These trails are designed, constructed, and maintained on a case-by-case basis. On-road cycling lanes are separated from other travel lanes by a painted line reflective tape or rumble strip. Lines should be painted or taped the same white colour as other roadway lane lines. Paint should be to Ontario Provincial Standards and Specifications (OPSS).
- Snowmobile trails
 - These trails can be designed, constructed, and maintained on a case-by-case basis as arranged by the Community Trails Committee in conjunction with the Ontario Federation of Snowmobiles, the Town and the Developer.

Proposed trails should link together local points of interest, all open space amenities, civic institutions and connect to the regional trails network. To the extent possible the route should be off-road, utilizing public open spaces, right-of-ways and easements.

Trails connecting through urban areas located within the road right-of-way should be paved multi-purpose cycle ways. Trails through sensitive natural features should be designed as soft surface paths and located to avoid fragile areas. Entrance points to the trail system should be marked with signage as required by the Town. All trails and walkways shall be approved by Council. Any proposed development affecting an existing trail, must have an interim/temporary trail in place during construction. Any works adjacent to or affecting the Georgian Trail shall be done in consultation with the Georgian Trail Board of Management.

3.5 Record Drawings

3.5.1 General

Upon completion of the construction of the Works or as requested by the Town, the Consultant shall obtain as-constructed field information and revise the original drawings accordingly and submit the same, as "Record Drawings".

All drawings shall be revised to reflect the "Record Drawing" condition for Works to be accepted by the Town. Lots and Blocks are to be numbered according to the Registered Plan and a separate distinct number for the municipal street address will be provided by the Town for incorporation into the "Record Drawings". Specific requirements for Storm System, Sanitary Sewers, Watermains and Roadways are noted in the following sections.

The drawings shall be sealed and signed by a Registered Professional Engineer and stamped "Record" and dated or provide appropriate wording that the undersigning Consulting Engineer is verifying and certifying that the works have been installed as described in the Record Drawings.

Drawings shall conform to the most recent requirements and AutoCAD standards of the Town.

3.5.2 Storm System

Actual storm system invert elevations shall be indicated on the "Record" drawings. If the difference is greater than 150 mm from the design vertical alignment, affected portions of the sewer or overland drainage route shall be redrawn in profile. Any maintenance hole which differs from the proposed horizontal location by more than 1.0m shall be redrawn in both plan and profile.

In addition, the following shall be indicated on the "Record" drawings:

- pipe/culvert size, grade, type, class/gauge, bedding;
- chainage from MH along main to service tees.

If the final grade of sewer differs by more than 5% of the design grade, the Consultant shall submit hydraulic calculations.

3.5.3 Sanitary Collection System

All actual sanitary sewer invert elevations shall be indicated on the "Record" drawings. If difference is greater than 150 mm from the design vertical alignment, affected portions of the sewer shall be redrawn in profile. Any maintenance hole which differs from proposed horizontal location by more than 1.0m shall be redrawn in both plan and profile.

In addition the following shall be indicated on the "Record" drawings:

- pipe size, grade, type, class, bedding;
- chainage from MH along main to service tees;
- dimensions from lot corners and elevations for service laterals.

If the final grade of sewer differs by more than 5% of the design grade, the Consultant shall submit hydraulic calculations.

3.5.4 Water Distribution System

All actual watermain obvert elevations at 40m intervals and vertical bends shall be indicated on the "Record Drawings". If the difference is greater than 150mm from design vertical alignment, affected portions of the watermain shall be redrawn in profile. If horizontal alignment changes exceed 0.5m the affected portions of the watermain shall be redrawn in plan.

In addition, the following shall be indicated on the "Record" drawings:

- pipe size, type, class, bedding;
- swing-ties to all main appurtenances (valves, bends, tees, etc);
- chainage from appurtenance along main to main stops;
- dimensions from lot corners and elevations for service laterals;
- tracer wire gauge

Separate from the "Record" drawings, the Consultant shall supply a list of all appurtenances, valves, curb stops, fire hydrants, etc. installed as part of the project.

3.5.5 Roadways

All actual roadway centre line elevations to a tolerance of 0.025 metres, at a maximum 20m interval, shall be indicated on the "Record" drawings. Gutter elevations shall be indicated for cul-de-sacs and intersections to show drainage into storm system. If horizontal road alignment changes more than 0.5m or vertical geometry changes greater than 150mm the plan and/or profile shall be redrawn as appropriate.

In addition, the following shall be indicated on the "Record" drawings:

- driveways, lay-byes, curb depressions;
- road signage;
- laneway marking and stop bar locations.

4 DESIGN AND CONSTRUCTION REQUIREMENTS

4.1 Introduction

The purpose of this section is to outline the minimum design requirements for the construction of municipal services in the Town. These requirements are general in nature and do not relieve the Consultant of the responsibility for submitting a completed project demonstrating competent engineering design in full compliance with all applicable legislation.

Any deviation from the minimum Town standards shall be specifically referred to by the Consultant with a copy of prior written approval of the Town attached.

4.2 Storm Water Management System

4.2.1 General

Stormwater quantity and quality must be satisfactorily addressed on all projects. The requirements of the Town, Ministry of the Environment, Grey Sauble Conservation Authority and Nottawasaga Valley Conservation Authority will apply. Stormwater management should conform to any applicable sub-watershed study.

Design and system selection must make reference to the Ministry of the Environment Storm Water Management Practice, Planning and Design Manual (2003) and its subsequent revisions.

Where curb and gutters are required, stormwater run-off shall be accommodated by a system of catch basins, manholes and storm sewers. The storm drainage system is to be designed to limit flood damage and hazards for non-frequent storm conditions, to provide a reasonable level of convenience and safety for pedestrian and traffic use by removal of lot and street surface run-off during frequent storm conditions and to prevent the impairment of water quality and disturbance to natural streams.

In all cases the designer must have regard for impacts on overland flow routes and receiving water courses. In all instances there shall be an adequate overland emergency flow route to the satisfaction of the Town.

4.2.2 Drainage Areas

Allowances shall be made for inflows from adjacent lands that naturally drain into or through the subject Works and the system shall be designed to service all areas within the project to their maximum future development in accordance with the Official Plan. The Stormwater Management design must account for the safe conveyance of the greater of the runoff rate generated during the 100 year storm or Regional event from the development area and external catchments draining through the property. In addition, the design must be completed

to ensure that there are no negative impacts to owners of upstream or downstream lands occurring as a result of the Works. The exact location for connecting sewers or channels to adjacent sewers or areas shall be approved by the Town's Engineer.

4.2.3 Easements

If the required drainage works from municipal lands or lands to be dedicated to the municipality result in drainage through other lands, all such work shall be carried out by means of a storm drain and appurtenances of sufficient size for the drainage requirements of the area. The design shall be based on the run-off to be expected from the area when completely developed with buildings, pavements, sidewalks and parking areas.

The width of any drainage easement shall be sufficient for the facility and maintenance thereof. The minimum easement widths are as follows:

- One sewer and/or swale – 6 metres
- Two sewers, same trench – 8 metres
- 2x depth of sewer invert
- As dictated by the Town

4.2.4 Drainage and/or Stormwater Management Report

The Drainage and/or Stormwater Management Report setting out the existing and proposed drainage system shall be submitted for approval to the Town's Engineer. The report may also have to be approved by the Ministry of the Environment, the Ministry of Natural Resources, the Grey Sauble Conservation Authority and Nottawasaga Valley Conservation Authority as appropriate. This report, among other things, shall pay particular attention to the following:

- (a) Possible areas within the development lands not having suitable drainage outlets.
- (b) The possible obstruction of natural drainage patterns by development and buildings.
- (c) Details of a suitable drainage outlet(s) from the development lands including all overland flow routes.
- (d) Natural watercourses entering the development lands and adjacent lands draining to the development lands.
- (e) Accumulated flows at all proposed drainage structures.

The report shall include a plan showing the major overland system design. When the Rational Method is used, the relevant figures are to be entered on Storm Sewer Design Sheets. When computer modeling is used, the report shall indicate model parameters and assumptions used to give outflow hydrographs and hydraulic grade line levels where applicable.

This report shall provide recommendations for dealing with all drainage which affects the

design of drainage works for the development and such recommendations, when approved, shall be incorporated into the Engineering Drawings.

4.2.5 Design Criteria

The storm water system is to be designed to provide convenience drainage for frequent storms (minor system) and flood protection from rare events (major system).

4.2.5.1 Minor System

Storm sewers and culverts are to be designed for at least a 5-year return frequency storm without surcharge where adequate overland drainage capacity exists to satisfy the major system requirements.

Exceptions to this may be considered when the major system is inadequate either because there is no outlet for overland flows or there is insufficient surface detention potential, the sewer system shall be designed to carry as much flow as necessary to achieve the minimum 100 year level of protection for the major system as specified below.

4.2.5.2 Major System

Run-off rates in excess of the design capacity of the minor system shall be conveyed via streets and swales to an appropriate outlet. The combination of overland flow system and minor system shall be designed for the greater of the 100 year return frequency storm or Regional event, to prevent flooding of private property with maximum level of road flooding and surface detention. The extent and the elevation of the 100 year storm ponding are to be shown on the grading plan(s). Maximum ponding depth is not to exceed 0.30 m. The allowable ponding shall be as defined below.

LOCATION	STORM RETURN FREQUENCY (YEARS)		
	5	25	100
Walkways and Open Spaces	Minor Surface Flow up to 25mm Deep On Walkways	As Approved for Overland Flow Outlets	As Approved for Overland Flow Outlets
Local Roads	Within the roadside ditch or 1.0 metres wide in gutter or 0.10 metres deep at low point catchbasin	Up to Crown	0.15 over Crown
Collector and Industrial Roads	Within the Roadside Ditch or 1.0m Wide in Gutter or 0.10m Deep at Low Point Catch Basins	Up to Crown	0.10m Above Crown for flows parallel to road. Water course are not to cross over top road
Arterial Roads	Within the Roadside Ditch or 1.0m Wide in Gutter or 0.10m Deep at Low Point Catch Basins	One Lane Clear	Up to Crown for flows parallel to the road Water course are not to cross over top road
Private Property	Minor Ponding In Swales	No Structural Damage, Minor ponding In Yard Areas	No Structural Damage, Ponding in Yard Areas Below Building Openings - No Basement Flooding No designed flooding of private lands without approvals.
Public Property	Minor Ponding in Swales or Ditches	No Structural Damage Ponding in Flat Areas No Erosion	No Structural Damage Ponding in Flat Areas Some Erosion permitted

Street grading must provide a continuous gradient to direct street flows to an adequate outlet at low points. Outlets can be walkways or open sections of roadways leading to parks, open spaces or river valleys.

4.2.6 Detention & Retention Facilities

Where deemed necessary by the Town to reduce run-off increases and to meet identified downstream flow and quality constraints, detention and/or retention facilities shall be provided

for both the major and minor systems.

Land area set aside expressly for stormwater management facilities where it is not part of a privately owned facility (ie. roof top storage or otherwise incorporated into industrial/commercial lands) shall be designated as a "stormwater detention/retention site" and dedicated to the Town. It shall not be considered as part of the park system.

Stormwater management areas subject to site plan approval, will be on lands retained by the owner.

4.2.6.1 Overflow Spillway

All stormwater management facilities shall be provided with an outlet (overflow spillway) designed to accommodate a 100-year return frequency storm flow without failure. Suitable erosion protection shall be provided downstream of the outlet for all flow conditions. Operation during spring snow melt or freezing conditions shall be investigated and any required changes shall be incorporated.

4.2.6.2 Dry Ponds

Stormwater management Dry Ponds shall be designed to limit the maximum depth of water to 1.8m above the lowest point of the stormwater basin. An additional 0.3 m freeboard is required above the maximum peak flow flood level. The maximum depth of the extended detention zone shall not exceed 1.0 m above the lowest part of the pond. A maximum 5:1 slope shall extend from the bottom of the pond to the limit of maximum extended detention, with a minimum horizontal length of 3.0 m. The minimum allowable gradient on the bottom of the basin shall be 1.0% and the maximum gradient shall be 5.0%.

4.2.6.3 Wetlands

Stormwater management Wetlands shall be designed to limit the maximum depth of water to 2.1 m above the lowest point of the stormwater basin excluding micro pools. An additional 0.3 m freeboard is required above the maximum peak flow flood level. The maximum depth of the extended detention zone shall not exceed 1.0 m above the permanent pool elevation. Maximum peak flow attenuation zone shall not exceed 1.8 m above the permanent pool elevation. The permanent pool depth shall range between a minimum depth of 0.15 m to a maximum depth of 0.3 m. A maximum 5:1 slope below the permanent pool level shall be permitted around the entire stormwater management pond. A maximum 5:1 slope above the permanent pool level shall be permitted around the entire stormwater management pond. The slope shall extend from the permanent pool level, to the limit of the maximum extended detention. The horizontal distance of this slope must be a minimum of 3.0 m. Micropools shall not exceed an additional maximum depth of 0.3 m below the permanent pool level. Micropools shall not exceed 5% of the total wetland permanent pool surface area.

4.2.6.4 Wet Ponds

Stormwater management Wet Ponds shall be designed to limit the maximum depth of water to 3.3m above the lowest point of the stormwater basin. An additional 0.3 m freeboard is required above the maximum peak flow flood level. The maximum depth of the extended detention zone shall not exceed 1.0 m above the permanent pool elevation. Maximum peak flow attenuation zone shall not exceed 1.8 m above the permanent pool elevation. The permanent pool depth shall range between a minimum depth of 1.0 m to a maximum depth of 1.5 m.

A maximum 5:1 slope below the permanent pool level shall be permitted around the entire stormwater management pond. The horizontal distance of this slope must be a minimum of 3.0 m. A slope commencing from this point to the lowest point of the stormwater basin shall be a maximum of 3:1. A maximum 5:1 slope above the permanent pool level shall be permitted around the entire stormwater management pond. The slope shall extend from the permanent pool level, to the limit of the maximum extended detention. The horizontal distance of this slope must be a minimum of 3.0 m.

4.2.6.5 Forebays

Forebays are required for all stormwater management facilities. The permanent pool depth shall range between a minimum depth of 1.0 m to a maximum depth of 1.5m in which a maximum depth of 0.5 m shall be used for sediment accumulation. Forebays shall not exceed 33% of the total Wet Pond surface area and 20% of the Wet Land permanent pool surface area. All other aspects regarding the design of forebays shall conform to the above Wet Pond standards. Excluding maintenance access routes, all access to forebays shall be discouraged through shrub plantings.

From the point of maximum extended detention, to the lower limits of the "Safety Separation" area or property line where it abuts private property, slopes shall vary between 2:1 to 6:1 and have a maximum average slope of 4:1; not including the maximum 10:1 maintenance access slope.

4.2.6.6 Landscaping

Native and non-invasive trees, shrubs, ground covers and aquatic plants are required in a low maintenance landscape design which has regard for the ecology of the site and the eco-region.

For Wet Ponds and Wetlands, all slopes 5:1 and steeper ranging from a minimum horizontal distance of 3.0 m from the permanent pool level to the property line (not including walkways and trails) shall be planted. For Dry Ponds, all slopes 5:1 and steeper ranging from a minimum horizontal distance of 3.0 m from the pool bottom level to the property line (not including walkways and trails) shall also be planted. Incorporating a wide range of slopes and ponding depths into facility design that conforms to the design criteria is strongly encouraged and desirable in order to facilitate a wide range of flora and fauna habitat conditions.

Where trees are to be planted, they must be planted at a minimum rate of 1 tree (40 mm cal) per 50 square metres. The density of shrub plantings, for safety purposes, shall vary depending on the degree of slope. Shrub planting shall prevent public access on all 2:1 slopes and discourage access on all 3:1 slopes.

4.2.6.7 Operating and Maintenance Manuals

Upon the request of the Town the designer shall provide an operating and maintenance for the proposed Storm Water Maintenance Facility(ies) .

4.2.7 Ditches and Culverts

Ditches and driveway culverts shall be sized to convey a 5 year storm. Road crossing culverts to be designed to convey a 25 year storm on Local and Collector roads and 100 year storm on Arterial roads. Where curb and gutter are not required, ditches shall be constructed as follows:

- (a) Culverts shall be constructed with low point of entrance or road over culvert.
- (b) Ditches shall be constructed to contain the 5 year storm event without flooding the road surface.
- (c) Depth below finished centreline grade shall be:
Maximum 1.5 m
Minimum 200 mm below bottom of granular to drain roadbed
- (d) Ditch grade shall be:
Maximum 6 percent
Minimum 0.5 percent, 1.0 percent in areas of high ground water
- (e) In exceptional cases and where ditches are on easements off the road allowance, ditches with grades greater than 6 percent may be allowed by the Town's Engineer but these shall be suitably protected against erosion by such means as rip-rap or gabions.
- (f) Ditches through easements exceeding 1.8 m in depth shall be fenced off with standard 1.8m high chain link fence or shall be constructed with 4:1 side slopes.
- (g) Where considered necessary by the Town's Engineer, ditches shall be piped.

The minimum ditch protection on all ditches shall be 100 mm of topsoil and staked sod on the side slopes and bottom of the ditch. The Town may consider the use of seed and mulch in place of nursery sod.

Ditch to ditch road cross culverts shall be installed where required as follows:

- Minimum Length - as required from centre of ditch to centre of ditch

- Minimum Size - 600 mm diameter
- Material - galvanized corrugated steel pipe
- Wall Thickness - as recommended by manufacturer for deep pipes, minimum wall thickness 2.0 mm (14 gauge)
- Cover - 300 mm minimum
- Bedding - Culverts shall be bedded and backfilled with granular material in accordance with Ontario Provincial Standards

Where it is necessary to construct culverts under roadways or driveways larger than the minimum size, the cross-sectional end area shall be calculated by an approved method as noted previously. The culverts shall be of reinforced concrete or corrugated steel and detail drawings and calculations shall be submitted for the approval of the Town's Engineer.

Driveway entrance culverts shall have a minimum diameter of 500 mm, a minimum wall thickness of 2.0 mm (14 gauge) and a minimum length of 7 m. Culverts for fire hydrant ramps, if required, shall have a minimum diameter of 500 mm and a minimum wall thickness of 2.0 mm (14 gauge). Larger diameter culverts may be required based on storm water management analysis.

4.2.8 Water Quality

Quality controls for runoff from proposed developments within the Town are to be provided to achieve treatment to an Enhanced level of protection as per the "Stormwater Management Planning and Design Manual" MOE, March 2003.

The selection of Best Management Practices (BMP) for water quality control shall be investigated as directed by the Town's Engineer. When selecting and designing BMP's, reference should be made to the Ministry of the Environment Storm Water Management Practices Planning and Design Manual (2003) and its subsequent revisions.

The BMP selection process shall review all environment constraints and provide rationale for the selection of alternatives for a specific site as outlined in detail in the above noted MOE document.

In all cases, infiltration of stormwater from rooftops and grassed areas by using dry wells, infiltration trenches, buffer zones, grass swales, etc. shall be the primary consideration for stormwater quality control. Infiltration areas would be subject to the recommendations of a hydrogeological and soils investigation report. Runoff from roadways and parking lots must be treated prior to infiltration or discharge to a watercourse. For developments where infiltration is not possible, or is limited, infiltration ponds for extended detention facilities shall be considered.

Wet facilities shall be considered only if all other BMP's have been proven not feasible or ineffective.

Designers are encouraged to incorporate quantity and quality control within a single structure with multiple chambers.

The Town does not have a specific method or combination of methods specified with regard to stormwater quality. Each design shall be evaluated on its merits.

4.2.8.1 Point Of Entry Control

In cases where the area of the development is not capable of facilitating the required quality control measures, point of entry traps shall be employed.

4.2.8.2 Oil/Grit Separators (OGS)

Oil/Grit Separators (OGS) can be used as a stand alone unit without the requirement of supporting quality management devices on a site specific basis. The OGS design shall be signed and sealed by a Professional Engineer (Registered in Ontario). The information required for review is as follows:

- Design calculations verifying the claimed performance
- Details and
- Maintenance requirements

The replacement of the approved OGS with an “equivalent” shall not be permitted without having the “equivalent” submitted for review and approval under the same site requirements.

4.2.9 Connections to Ditch and Storm Sewers

4.2.9.1 General

Rain water leaders, house perimeter tile drains, trench drains or sump pump pipes, shall not be discharged directly to the roadside ditches.

4.2.9.2 Outfalls

Outfall structures to existing channels or water courses shall be designed to prevent erosion or damage in the vicinity of the outfall from maximum design flows. Headwalls shall be provided for all outfalls 400 mm and larger.

4.2.9.3 Roof Leaders

Leaders are to be discharged to the ground surface to splash blocks and flows to be directed away from the building in such a way as to prevent ponding or seepage into weeping tile. Where flat roofs are used, as in commercial or industrial sites, detention roof hoppers requiring smaller or fewer roof leaders may be used as part of the stormwater management design. No connections are to be installed directly to storm or sanitary sewers or outletted to roadside

ditches.

4.2.9.4 Foundation Drains

It is the Town policy that foundation drains shall not be connected directly to the Town sewer systems. A sump pump system shall discharge to a 100 mm residential storm sewer connection. Where storm sewer connections are not available, the sump pump system shall discharge to a concrete splash pad in a landscaped area and with the water directed to side yard swales. The geotechnical report shall consider the ground water table elevation and recommend minimum basement elevations. Foundation drain discharge water that becomes a nuisance shall be corrected.

Basement floor slabs must be a minimum of 0.3 m above seasonal high ground water table.

4.2.9.5 Storm Connections

All newly proposed residential developments with storm sewers will be required to provide a storm sewer connection to all residential dwellings. The residential storm sewer will be oversized to accommodate these additional flows.

Residential storm connections shall be PVC 100 mm SDR28 colour white.

Residential storm connections shall terminate at 1.0 m right of sanitary connection (when facing lot) with a gasketed cap/plug and an 89 mm x 38 mm marker painted white.

4.2.9.6 Municipal Drains

Where development proposals include any sort of alterations to a municipal drain, the laws, regulations and specifications of the Ontario Municipal Drainage Act shall be strictly adhered to and the design specified by the Engineer's report for the Municipal Drain shall be met.

4.2.9.7 Temporary Erosion and Sediment Control

Temporary erosion and sediment control measures during construction must be addressed on all projects.

All silt fences must be constructed as per OPSD 219.130, heavy duty silt fence.

The requirements of the Town, Ministry of Environment, Nottawasaga Valley Conservation Authority and Grey Sauble Conservation Authority will apply and any other applicable authority.

The Designer shall consider the sensitivity of the downstream environment and the availability of on-site retention facilities when determining erosion and sediment control measures.

The Stormwater Management and Erosion Control Plan(s) shall include the control measures

required to prevent erosion and sediment control resulting from mud tracking onto municipal streets, windblown dust, and waterborne sediments entering the municipal sewer system.

The control measures shall be monitored and properly maintained during construction and until such time as the control measures are no longer required. Maintenance shall include the removal of sediment accumulated by the control measures.

Should the proposed control measures prove to be ineffective, then other methods and controls shall be added subject to the approval of the Town's Engineer.

4.2.10 Storm Water Management System

4.2.10.1 Design Flows

Potential increases in run-off rates of any storm event, resulting from new development on the project shall be controlled to pre-development run-off rates. Where downstream constraints exist such as those established by the Town or the Conservation Authority, the drainage report shall demonstrate how run-off rates will be controlled to satisfy those constraints. In the absence of such constraints, the post-development flows generally shall not exceed the flows for pre-development conditions for the same storm event at the outlet unless it is demonstrated to the satisfaction of the Town's Engineer that uncontrolled flows will have no adverse effects.

4.2.10.2 Methods of Computation

Pre-development peak flows shall be computed by a method such as the Rational Method or by an approved computer model. Watershed definition and pre-development flows must be approved by the Town's Engineer.

Preliminary estimates of post-development flow rates may be computed using a method such as the Rational Method.

Where:

- $Q = 2.78ACI/1000$
- $Q = \text{flow (m}^3/\text{s)}$
- $A = \text{area (ha)}$
- $C = \text{run-off Coefficient}$
- $I = \text{intensity (mm/hr)}$

For all systems and for the design of surcharged sewers and detention facilities, the latest version of the computer model OTTHYMO is recommended. Other hydrograph methods may be considered if it is demonstrated that the results are comparable to those from OTTHYMO. Post-development design flows may be determined using the Rational Method only where the design area is less than 40 hectares and run-off control facilities are not considered.

Rainfall intensity-duration-frequency equations or their curves and design storm hydrographs shall be based on the Owen Sound Rainfall Intensity chart.

4.2.10.3 Time of Concentration

Where the first leg of a residential storm sewer system is sized using the Rational Method, the initial inlet time shall be 15 minutes for the 5-year storm. This shall apply where the upstream drainage area does not include large open space areas. Where peak flows from external areas enter a subdivision sewer system, the more critical case based on either the time of concentration including the external area or the time of concentration excluding the external area shall be used. Actual velocities of computed peak flows shall be used to estimate time of concentration. Calculations for time of concentration should be based on the Airport or Bransby-Williams formula as per recommendations of the MTO Drainage Management Manual. For areas where the slope exceeds 10 percent, the values established in the preceding calculations are to be used directly rather than rounded up.

A design evaluation of inlet times must be submitted to justify inlet times different from those specified above, especially in the cases where the sewer is designed for certain surcharge peaks for larger storms and where the sizing is optimized for both situations. Such an evaluation shall be approved by the Town's Engineer prior to submission of design drawings.

4.2.10.4 Surface Run-off Coefficient

Surface run-off coefficient for the Rational Method are given by component of surface treatment and by Land Use. The Land Use values provided are intended as a guide only. The Designer is encouraged to develop an appropriate co-efficient using a composite calculation, which is subject to the approval of the Town's Engineer.

Description	C ₅
Sodded area under 7% slope	0.30
Sodded area over 7% slope	0.40
Paved Area with Storm Sewer	0.90
Paved Area with Sodded Swales (Dependent on Relative Area of Swale to Paved Area and on Type of Swale)	0.45 - 0.85
Gravel Area	0.75
Roof Area	0.90
Flat Roof Area with Detention Hoppers	0.10 - 0.50
Residential Lots	0.45 - 0.55
Commercial Lots	0.40 - 0.85
With Any Roof Leaders or Pavement to Sodded Areas	
Unimproved Open Space Under 7% Slope	0.25
Unimproved Open Space Over 7% Slope	0.35

For estimating flows from storms larger than the 5-year return storm, the run-off coefficients should be increased to account for the increase in run-off due to saturation of the soil, with the estimate becoming less accurate for larger storms. Coefficient for the larger storms can be derived as follows:

$$\begin{aligned} C_{10} &= (0.8 \times C_5) + 0.2 \\ C_{25} &= (0.7 \times C_5) + 0.3 \\ C_{50} &= (0.6 \times C_5) + 0.4 \\ C_{100} &= (0.5 \times C_5) + 0.5 \end{aligned}$$

In general, a storm sewer system shall be designed to convey not less than the 5-year return frequency storm without surcharge. Surcharged design may be considered for higher design levels where suitable methods are used. Foundation drains are not to be connected to the storm sewer.

4.2.10.5 Rainfall Intensity

4.2.10.5.1 Owen Sound IDF

Intensity Duration Frequency (IDF) Curves for the Owen Sound area are attached as Appendix 'C' to this document. The curves are derived using the following variables and formula:

$$I = A \times T^B$$

Where:

A = coefficient from chart (unitless)

T = time (hr)

B = coefficient from chart (unitless)

I = rainfall intensity (mm/hr)

Design Storm	A	B
2 yr	22.3	-0.714
5 yr	29.1	-0.724
10 yr	33.6	-0.729
25 yr	39.3	-0.734
50 yr	43.5	-0.736
100 yr	47.7	-0.738

4.2.10.5.2 Chicago Storm Parameters

Most computer modeling programs use the “Chicago Storm” as the default method of simulating rainfall events. For the Owen Sound area, the parameters for modeling using the Chicago storm are as follows:

CHICAGO DESIGN STORM	2 yr	5 yr	25 yr	100 yr
Max. storm duration (min.)	180	180	210	210
Max. hydrograph length (min.)	360	360	360	360
Time step (min.)	5	5	5	5
Coefficient (a)	854.100	1234.576	1750.276	2171.754
Constant (b)	7.781	8.297	8.303	8.303
Exponent (c)	0.830	0.851	0.862	0.867
Fraction (r)	0.375	0.375	0.375	0.375
Duration t_d (min.)	180	180	210	210
Maximum Intensity (mm/hr)	101.673	134.692	165.718	202.862
Total Depth (mm)	33.228	42.929	59.007	71.271

Rainfall intensity formula for this application:

$$I = a / (t + b)^c$$

Where:

a = Coefficient in Chicago Design Storm chart (unitless)

b = Constant in Chicago Design Storm chart (unitless)

c = Exponent in Chicago Design Storm chart (unitless)

t = time (minutes)

I = Rainfall intensity (mm/hr)

4.2.10.6 Storm Sewer

4.2.10.6.1 Pipe Capacities

Manning’s Formula shall be used in determining the capacity of all storm sewers. The capacity of the pipe shall be determined under the condition that the pipe is running full.

The value of the roughness coefficient (n) used in the Manning’s Formula shall be as follows:

Concrete pipe, all sizes	0.013
Concrete box culverts	0.013
Corrugated metal pipe	0.024
PVC pipe	0.009

4.2.10.6.2 Flow Velocities

Minimum allowable velocity = 0.75 m/s

Maximum allowable velocity = 4.50 m/s

4.2.10.6.3 Minimum Pipe Size

The minimum allowable pipe size for mainline storm sewer shall be 300mm.

4.2.10.6.4 Minimum Grades

Regardless of the designed flow velocities achieved, the minimum design grades for storm sewer pipe shall be as follows:

Pipe Diameter	Minimum Grade
300mm to 375mm	0.50%
450mm to 525mm	0.30%
600mm to 1200mm	0.20%
1200mm and Greater	0.15%

4.2.10.6.5 Changes in Pipe Size

In no case shall the downstream pipe size be smaller in diameter than that of the upstream pipe regardless of increase in grade.

4.2.10.6.6 Radial (Curvilinear) Pipe

Manufactured radial pipe shall be allowed for all storm pipes sized 900 mm in diameter or larger. A maintenance hole shall be located at the beginning and the end of the radial pipe section.

4.2.10.6.7 Location

The storm sewer location shall be as shown on the Town's Engineering Standards road cross section drawings. In the case of crescents or looped streets the storm sewer location can be varied to avoid crossing interference with the sanitary sewer.

4.2.10.6.8 Minimum Cover

The depth of storm sewers shall be sufficient to allow for the drainage of adjacent properties having internal stormwater management systems outletting to the mainline system. The minimum cover to the top of the outside barrel shall be no less than 1.5 m from the centerline of the roadway. In cases where the road centerline is no longer relevant, minimum cover to the

top of the outside barrel shall be no less than 1.3 m. Provisions are not required for downspout or foundation drain collection as it is not a permitted connection to the storm sewer.

4.2.10.6.9 Pipe Crossings

A minimum crossing clearance of 300 mm shall be provided between the outside barrels at all points of crossing. In the case where the sewer is to cross over a previously disturbed trench the sewer is to be adequately supported to prevent settlement of the sewer. Where the proposed sewer is to be installed beneath a previously disturbed trench that trench will be adequately supported to prevent settlement of the trench.

4.2.10.6.10 Limits

All sewers shall be terminated at the project limits using maintenance holes when external drainage is considered in the overall design of the sewer system. Maintenance holes at the limit of the development shall be designed for the future extension of the sewer.

4.2.11 Materials

Storm sewer pipe shall be constructed of concrete or PVC. The type and class of the sewer pipe along with the bedding classification shall be shown for each length in the profile of the plan and profile drawings.

All pipes to be joined with a gasketed bell and spigot system.

PVC pipe shall be used in accordance to OPSD 806.040 excluding the use of DR 41.

Non-reinforced concrete pipe may be used for sizes of mainline sewer up to and including 375 mm.

Reinforced concrete pipe may be used for all sizes of mainline sewer.

4.2.12 Pipe Bedding

The appropriate bedding class shall be selected from the OPSD with regard to the type of pipe being specified. (OPSD 806.040 as pipe strength may be surpassed due to exceeding the specified trench width.) If the specified trench width were to be exceeded during construction, a stronger pipe or an increase in bedding material shall be required.

4.2.13 Maintenance Holes

Concrete maintenance holes shall be provided at all changes in direction or junctions of the sewer and at all street intersections.

4.2.13.1 Maximum Spacing

The maximum spacing between maintenance holes shall be as follows:

Pipe Size	Max. Maintenance hole Spacing
300 mm	95 m
375 mm to 750 mm	100 m
825 mm to 1200 mm	125 m
1200 mm and Greater	150 m

4.2.13.2 Materials

Storm Maintenance holes shall be constructed of precast or poured concrete and shall be a minimum of 1200 mm inside diameter. The Ontario Provincial Standard 700 series Drawings shall be used for maintenance hole design where applicable. The Designer is to analyze each maintenance hole applying the OPSD related to soil conditions, ground water, loading, and other pertinent aspects to determine structural suitability. In the cases where the OPSD are not adequate, the maintenance hole(s) shall be individually designed and detailed.

Reference shall be made on the plan and profile drawings regarding the type and size of all maintenance holes. In the case of a standard 1200 mm precast maintenance hole, referring to OPSD 701.010 will suffice.

4.2.13.3 Maintenance Hole Design

- All maintenance hole chamber openings shall be located such that the ladder rungs are over the raised portions of the benched bottoms. In no case shall a ladder rung be placed in front of any portion of the inlet or outlet barrels.
- The direction of the flow in any maintenance hole shall not be permitted at acute interior angles.
- Safety grates shall be provided in all maintenance holes exceeding a depth of 5 m. The maximum spacing between safety grates is not to exceed 4.5 m.
- The obvert of the outlet pipe shall not be higher than the obvert of the inlet pipe(s) at any maintenance hole location.
- In the case of sewers 900 mm and greater the change in direction of flow in any maintenance hole shall be no more than 45°.
- Where the difference in elevation between the inlet invert and outlet invert exceeds 900 mm, a drop structure shall be placed on the inlet side of the maintenance hole.
- All storm maintenance holes shall be benched as per OPSD 701.021. In the case where OPSD 701.021 does not apply a detailed drawing will be shown on the plan and profile drawing that the maintenance hole is subject to.
- The minimum width of benching in all maintenance holes shall be 230 mm
- Minimum size of any maintenance hole stack shall be 685 mm x 685 mm.
- Maximum height of maintenance hole entry rings (Mod-u-loc) is 450 mm before

another precast concrete maintenance hole structure ring is necessary.

- The maximum offset from vertical in maintenance hole entry rings is 50 mm.

4.2.13.4 Head Losses

Appropriate drops shall be afforded across all maintenance holes to compensate for the loss of energy inherent to changes in flow velocity and changes in flow depths in sewers.

In general changes in velocity between the inlet and outlet pipes shall be no greater than 0.6 m/s.

Hydraulic calculations shall be provided when maintenance holes with outlet pipes of 900 mm in diameter and larger are required. Upon the request of the Town, hydraulic calculations may be required for maintenance holes with outlets smaller than 900 mm.

Regardless of the drop across a maintenance hole required by design calculations, the obvert of the outlet pipe shall not be higher than the obvert of the inlet pipe(s) at any maintenance hole location.

The minimum drops across maintenance holes shall be as follows:

Change in Horizontal Direction	Minimum Drop
0° (no change)	20 mm
1° to 45°	50 mm
46° to 90°	80 mm

The change in direction of the inlet(s) and outlet pipes shall always be 90° or less. In the case of sewers 900 mm and greater, the change in direction of flow in any maintenance hole shall be not more than 45°.

4.2.13.5 Grates for Maintenance Hole Frames and Covers

All maintenance holes located within the travelled portion of the roadway shall have the rim elevation set flush with the surface of the base course of asphalt. The setting of the frame and cover shall be constructed in accordance with OPSD 704.010.

The maintenance hole frames and covers are to be raised using concrete maintenance hole entry rings (mud-u-loc) prior to the placement of the top course of asphalt.

4.2.14 Catchbasins

Catchbasin leads shall be connected to the main sewer through a maintenance hole except where the main sewer size is 900 mm or greater in diameter, in which case the lead can be connected directly to the main sewer in the top half of the pipe using saddles and straps.

4.2.14.1 Location and Spacing

Catchbasin type shall be selected, located and spaced as per the requirements of the design. The catchbasin type and location shall take into consideration roadway area, roadway grade, lot area and lot grades, driveway locations and intersection locations. Catchbasins shall be provided on both sides of the street and double catchbasins shall be provided at all sags. The maximum catchbasin spacings are as follow:

Asphalt Width	Road Grade	Max. Spacing
> 11 m	$\leq 4.5\%$	75 m
> 11 m	> 4.5%	60 m
≤ 11 m	$\leq 4.5\%$	90 m
≤ 11 m	> 4.5%	75 m

Catchbasins shall be located upstream of pedestrian crossings and upstream of sidewalk crossings at intersections. Catchbasins shall not be located in driveway curb depressions, whenever possible.

Double catchbasins shall be used when flow is encountered from more than one direction where the total distances from each highpoint is greater than that allocated in the Max. spacing chart above. Double catchbasins will not be used to increase catchbasin spacing.

Rear yard catchbasins and connections shall be located as detailed in the Lot Grading Criteria.

4.2.14.2 Catchbasin Types

Catchbasins shall be constructed of precast or poured concrete.

Single, double, and catchbasin maintenance holes shall be specified as per OPSD. Rear yard catchbasins are to be specified as such, but detailed as the design appropriate OPSD.

The maximum catch basin height measured from the top of grate to pipe invert shall not exceed 2.4 m. Otherwise maintenance hole catch basins with 300 mm sumps shall be used.

All street line catchbasins shall have a 600 mm sump.

All rear yard catchbasins shall be benched.

All special catchbasin or inlets shall be designed and detailed by the Designer.

4.2.14.3 Catchbasin Connections

The minimum catchbasin lateral sizes shall be 300mm dia.

In general, catchbasins located in close proximity to a maintenance hole shall have the lead connected to the maintenance hole and benched accordingly. Long catchbasin leads in excess of 90 meters shall be connected to a maintenance hole or alternatively the 600 mm x 600 mm catchbasin shall be replaced with a 1200 mm catchbasin maintenance hole. Catchbasins are not to be used in series and local stormwater systems are only to connect to a maintenance hole structure (minimum 1200 mm diameter) or mainline tee.

4.2.14.4 Grates

The frame and cover for catchbasins shall be as per OPSD. In general, OPSD 400.020 shall be installed for all catchbasins located within the roadway, rear yard applications, pedestrian pathways or parkland. OPSD 403.010 shall be installed for all ditch inlet catchbasins. "Birdcage" style grates as per OPSD 400.120 shall be used in rear yard catchbasins or as indicated by the Town. Inlet structures with grates shall be designed to allow entry of design flow at 50% blocked. Where the catchbasin receives open channel flow that may be subject to debris, the Town may specify a custom grate and a larger lead size.

4.2.14.5 Catchbasins at Intersections

All catchbasins at intersections shall be located on the tangent section of the curb, a minimum of 1.0 m distance from the beginning or end of the curb radius on upstream side of sidewalk crossing.

4.2.14.6 Catchbasin Riser Rings

The maximum offset from vertical in catchbasin entry rings is 50 mm.

4.2.15 Inlets, Outfalls and Special Structures

For most design solutions, the Town requires the use of OPSD inlet and outlet structures, frames and grates. In cases where the Designer's solution requires a special inlet or outlet structure the Designer shall fully design the structure.

Inlet conveyance systems and outlet conveyance systems are to be fully designed to protect against channel morphology. The extent of the protection shall be specified on the engineering drawings and shall depend on velocity at the inlet/outlet and their ability to provide a laminar transition, soil conditions, the existing base flows and site characteristics.

4.2.16 Open Channels

Generally, open channels shall not be considered by the Town unless the flow exceeds 10 m³/s. All open channels shall be designed to convey the 100 year return storm flow with a free board 0.20 times the depth.

Scouring velocity of the cover materials and vegetation shall be considered. The velocities of

stormwater in swales or open channels shall be calculated and submitted as a component of the Stormwater Management Report.

The proposed rationale for an open channel shall be submitted to the Town's Engineer for approval prior to the detailed design. The Consulting Engineer shall also be responsible for obtaining approval from the authorizing Conservation Authority, the Ministry of Natural Resources, and the Ministry of the Environment.

4.3 Sanitary Sewer System

4.3.1 Design

4.3.1.1 Design Flows

Residential:

Flows to be designed in accordance with the M.O.E. Guidelines for the Design of Sanitary Sewage Works (latest edition) and the requirements below

Average Flow = 450 L / capita / day *exclusive of extraneous flows*

Peak Extraneous Flow = 0.23 L/s/ha

Peak Flow = $\frac{MQP}{86.4} + I \times A$ (L/s)

Where: $M = \text{Peak factor} = 1 + \frac{14}{4 + P^{0.5}}$ "Harmon Formula"

Q = Average daily per capita domestic flow (L/ capita / day)

P = Design Population / 1000

I = Unit of peak extraneous flow (L/s/ha)

A = Tributary area (ha)

Commercial / Institutional:

Commercial / Institutional	= 100 persons / ha
Hospitals	= 900-1800 L / bed / day
Schools	= 70-140 L / student / day
Church	= 100 persons / ha
Motels	= 150-200 L / bed / day
Hotels	= 225 L / bed / day

Note: All Commercial / Institutional flow information is exclusive of extraneous flows.

Industrial:

Light Industrial	= 20000 L / ha / day
Heavy Industrial	= 55000 L / ha / day

Note: All Industrial flow information is exclusive of extraneous flows.

4.3.1.2 Population Density

Population density to be determined from maximum unit density permitted under the Official Plan or actual unit count, whichever is the largest, multiplied by the average unit population. The average number of persons per unit regardless of density is 2.3.

4.3.1.3 Future Sanitary Sewer Requirements

Future land use and population shall be based on The Blue Mountain Official Plan. The system shall be designed to service all areas within the project to their maximum future development in accordance with the Town's Official Plan. Allowance shall be made for inflows from the appropriate adjacent contributing area. Discharges of the system are to be into appropriate sewers and are to be approved by the Town. The exact location for connecting to sewers in adjacent subdivisions or areas shall be as approved by the Town.

4.3.2 Sewer Pipe

4.3.2.1 Minimum Pipe Size

The minimum allowable pipe size for mainline sanitary sewer shall be 200 mm.

4.3.2.2 Minimum Grades

Regardless of the flow velocities achieved, the minimum design grades for sanitary sewer pipe shall be as follows:

Sewer Size	Minimum Grade
200 mm – 300 mm	0.50%
375 mm – 675 mm	0.40%
750 mm – 825 mm	0.30%

The first leg of any sewer regardless of size shall be 1.00%

4.3.2.3 Pipe Capacities

Manning's Formula shall be used in determining the capacity of all sanitary sewers. The capacity of the pipe shall be determined under the condition that the pipe is running full.

The value of the roughness coefficient (n) used in the Manning's Formula shall be 0.013.

4.3.2.4 Flow Velocities

For circular pipes (flowing full) the minimum acceptable velocity is 0.75 m/s and the maximum acceptable velocity is 3.0 m/s. The minimum velocity for sewers operating partially full shall result in self-cleansing equivalent to that produced by flow in sewer operating full at a velocity of 0.6 m/s.

4.3.2.5 Changes In Pipe Size

In no case shall the downstream pipe size be smaller in diameter than that of the upstream pipe regardless of increase in grade.

4.3.2.6 Head Losses

Appropriate drops shall be afforded across all maintenance holes to compensate for the loss of energy inherent to changes in flow velocity and changes in flow depths in sewers.

In general changes in velocity between the inlet and outlet pipes shall be no greater than 0.6 m/s.

Regardless of the drop across a maintenance hole required by calculations, the obvert of the outlet pipe shall not be higher than that of the obvert of the inlet pipes at any maintenance hole location.

The minimum drops across maintenance holes shall be as follows:

Change in Horizontal Direction	Minimum Drop
0° (no change)	30 mm
1° to 45°	50 mm
46° to 90°	80 mm

The change in direction of the inlet(s) and outlet pipes shall always be 90° or less. In the case of sewers 900 mm and greater the change in direction of flow in any maintenance hole shall be not more than 45°.

4.3.2.7 Location

The sanitary sewer location shall be as shown on the Engineering Standard Design road cross section drawings. Generally the location is in the centerline of the roadway.

4.3.2.8 Minimum Cover

Sanitary sewers shall be buried a minimum of 1.0 m below basement floor elevations where possible to allow for the installation of sewer laterals. In areas of no sanitary sewer connection the sewers shall have a minimum frost cover of 1.6 m.

4.3.2.9 Pipe Crossings

A minimum crossing clearance of 300 mm shall be provided between the outside barrels at all points of crossing. In the case where the sewer is to cross over a previously disturbed trench the sewer is to be adequately supported to prevent settlement of the sewer. Where the proposed sewer is to be installed beneath a previously disturbed trench that trench will be adequately supported to prevent settlement of the trench. The sanitary sewer connections are required to go under the storm sewer.

4.3.2.10 Limits

All sewers shall be terminated at the project limit using maintenance holes when external drainage is considered in the overall design of the sewer system. Maintenance holes at the limit of the project shall be designed for the future extension of the sewer.

4.3.3 Materials

Sanitary sewer pipe shall be constructed of PVC. Concrete or HDPE may be considered in some applications. All sanitary sewer pipes shall conform to the requirements of CSA and OPSS.

For sewer applications requiring pressure pipe, pipe design should reference MOE guidelines.

The type and class of the sewer pipe along with the bedding classification shall be shown for each length on the plan and profile drawings.

PVC pipe shall be used in accordance to OPSD 806.040 excluding the use of DR 41.

4.3.4 Pipe Bedding

The appropriate bedding class shall be selected from the OPSD with regard to the type of pipe being specified. If the specified trench width were to be exceeded during construction, a stronger pipe or an increase in bedding material shall be required.

In areas where it is difficult to control the infiltration of ground water into the sewer trenches, a clear stone may be used provided it is wrapped in a suitable geotextile, selected and installed in accordance with the manufacturer's requirement.

4.3.5 Sanitary Maintenance Holes

Maintenance holes shall be located at each change in alignment, grade or pipe material, at all pipe junctions, and at regular intervals along the pipe to permit entry for maintenance to the sewer.

4.3.5.1 Maximum Spacing

The maximum spacing between sanitary maintenance holes shall be as follows:

Pipe Size	Max. Maintenance hole Spacing
200mm to 750mm	100m
750mm to 1200mm	125m
1200mm and Greater	150m

4.3.5.2 Maintenance Hole Types

Maintenance holes shall be constructed of precast or poured concrete. The Ontario Provincial Standard 700 series Drawings shall be used for maintenance hole design where applicable. The Consulting Engineer is to analyze each maintenance hole applying the OPSDs related to soil conditions, ground water, loading, and other pertinent aspects to determine structural suitability. In the cases where the OPSDs are not adequate, the maintenance hole(s) shall be individually designed and detailed and stamped by an engineer.

Reference shall be made on the plan and profile drawings regarding the type and size of all maintenance holes. In the case of a standard 1200 mm precast maintenance hole, referring to OPSD 701.010 will suffice.

4.3.5.3 Maintenance Hole Design

- All maintenance hole chamber openings shall be located such that the ladder rungs are over the raised portions of the benched bottoms. In no case shall a ladder rung be placed in front of any portion of the inlet or outlet barrels.
- The direction of the flow in any maintenance hole shall not be permitted at acute interior angles.
- Safety grates shall be provided in all maintenance holes exceeding a depth of 5 m. The maximum spacing between safety grates is not to exceed 4.5 m.
- The obvert of the outlet pipe shall not be higher than that of the obvert of the inlet pipes at any maintenance hole location.
- In the case of sewers 900 mm and greater the change in direction of flow in any maintenance hole shall be no more than 45°.
- Where the difference in elevation between the inlet invert and outlet invert exceeds 900 mm, a drop structure shall be placed on the inlet side of the maintenance hole.
- All storm maintenance holes shall be benched as per OPSD 701.021. In the case

where OPSD 701.021 does not apply a detailed drawing will be shown on the plan and profile drawing that the maintenance hole is subject.

- The minimum width of benching in all maintenance holes shall be 230 mm
- Minimum size of any maintenance hole stack shall be 685 mm x 685 mm.
- The maximum height of maintenance hole entry rings (i.e. Mod-u-loc) is 450 mm before an additional precast concrete maintenance hole riser section is necessary.
- The total maximum offset in maintenance hole entry rings is 50 mm.

4.3.5.4 Grates for Maintenance Hole Frames and Covers

All maintenance holes located within the travelled portion of the roadway shall have the rim elevation set flush with the surface of the base course of asphalt. The setting of the frame and cover shall be constructed in accordance with OPSD 704.010.

In cases where sanitary maintenance holes are located in areas where storm water surface ponding is designed to take place a water tight maintenance hole cover shall be used as per OPSD 401.050.

The maintenance hole frames and covers are to be raised using concrete rings prior to the placement of the top course of asphalt.

4.3.6 Sanitary Service Connections

Sanitary service connections are to have a minimum of 2.0% slope at all sections of the service connection.

Sanitary connections are to be sized in accordance with the following sizes:

Single family residential:

single 125 mm diameter (min.) PVC SDR 28 Current requirement

Multiple family residential block, institutional, commercial and industrial blocks:

designed to convey expected peak flow;

Min. size 200 mm diameter.

Sanitary connections shall be in accordance with the following Standards:

OPSD 1006.010 Sewer Service Connection for Rigid Pipe;

OPSD 1006.020 Sewer Service Connection for Flexible Pipe.

Residential connections shall terminate at the center of the property line with a test fitting, 125 mm x 100 mm reducer, plug suitably braced to withstand test pressures and 89 mm x 38 mm marker placed from the invert of the connection to 600 mm above grade painted green.

4.3.7 Testing and Acceptance

The complete sewer system including service connections to the property line and maintenance holes shall be tested in accordance with OPSS. Deformation gauge (Pig) test as per OPSS is required on all pipe works prior to Town acceptance. All pipe works shall have a CCTV inspection as per OPSS 409 completed as part of the preliminary and final acceptance inspections.

4.4 Water Supply System

4.4.1 Watermain Design

4.4.1.1 General

The proposed design must consider and be able to convey all water needs for the project under consideration and adjacent lands. The phasing of any construction or implementation must be in a manner to provide orderly and reliable water distribution systems within the development, looping of these systems shall be provided to the satisfaction of the Town.

Watermains shall be designed to carry the maximum day demand plus fire suppression flows or peak hour flow whichever is greater.

A hydraulic network analysis of the water distribution system shall be carried out and shall include allowances for demands to adjacent areas anticipated.

4.4.2.1 Demand Criteria

The average daily demand is to be 450 litres/capita/day. The estimated populations and areas for the different neighbourhoods shall be in accordance with The Blue Mountains' Official Plan or the actual unit count multiplied by 2.3 persons/unit.

The maximum day and peak hour factors shall be determined from the current MOE design guidelines although the following are considered minimums:

- Maximum daily demand factor: 2.0
- Peak hourly demand factor: 4.5

Flows and peaking factors for industrial, commercial and institutional land uses shall be determined on an individual basis.

4.4.2.2 Fire Suppression

Water demand for fire suppression shall be determined from the Fire Underwriters Survey (FUS), latest edition dependent on the actual land uses. If the actual land use is not known, the water demand for fire suppression shall be determined from the maximum possible depending on the current zoning or as directed by the Town. Where there is evidence acceptable to the

Town that FUS level of fire protection will be available within 5 years, the interim level of available fire flow can be reduced to that required under the Ontario Building Code (OBC).

4.4.2.3 Frictional Losses

The Hazen-Williams formula shall be used for computing friction losses and subsequently sizing the watermains. For new mains the values of "C" coefficient shall be 110 for 150 mm diameter pipe, 120 for 200 mm diameter pipe and 130 for larger.

4.4.2.4 Minimum Size

The minimum size of mains shall be 150 mm in diameter in residential subdivisions and 200 mm diameter in industrial developments.

4.4.2.5 Maximum Velocity

The maximum velocity in the watermain under all flow conditions shall not exceed 5.0 m/s.

4.4.2.6 Permissible Pressure Ranges

The permissible pressure range for varying demand events are as followed and are measured at the centreline road elevation.

Average and Maximum Day:	350 – 550 kPa (50 – 80 psi)
Minimum and Peak Hour:	275 – 700 kPa (40 – 100 psi)
Maximum Day plus Fire Suppression:	140 – 700 kPa (20 – 100 psi)

Where the topography is such that the pressure at the centreline road elevation will be greater than 550 kPa (80psi), an individual pressure reducing device will be required on each water service.

In instances where all services are protected by an individual pressure reducing device, the maximum pressure in the watermain system shall not exceed 825 kPa (120 psi). The use of individual reducing valves shall be pre-approved by the Town.

4.4.3 Depth of Watermains

The minimum ground cover on watermains service laterals and hydrant leads shall be 1.7 m at all points or 1.2 m with a pre-approved insulation procedure. The maximum ground cover shall be 2.5m unless approved by the Town.

4.4.4 Separation of Watermains and Sanitary Sewers

Minimum separation between watermains and sanitary sewers shall be provided in accordance with MOE guidelines.

4.4.5 Location

The watermain shall be located as shown on The Blue Mountains standard road cross section drawings.

4.4.6 Pipe Classification and Bedding

Watermains shall be PVC DR18.

4.4.7 Bedding

Pipe embedment and backfill shall be as per OPSS and OPSD.

4.4.8 Thrust Blocks and Joint Restraints

Thrust blocks or joint restraints shall be required at all changes in pipe direction, terminations and any location where thrust pressures may occur. Where soil conditions are suspect, such as in disturbed soils or soils with bearing strength of less than 200 kPa, pipe restrainers shall be used.

The use of threaded rod in joint restraint is not permissible.

Serrated (machined) ring type joint restraints for PVC shall meet the requirements of Uni-Bell B-13 or ASTM F1674, and AWWA C-111 where appropriate, and be listed by ULc or FM. Accepted products include Clow (Series 300, 350, 360), Ebaa (Series 1600, 2500, 2800), Sigma (PV Lok PVP, PVM, PVPF) and UniFlange (Series 1300, 1350, 1360). Wedge action type joint restraints for PVC pipe shall meet the requirements of Uni-Bell B-13 or ASTM F1674, and AWWA C-111 where appropriate, and be listed by ULc or FM. Accepted products include Ebaa (series 2000PV), Sigma (One lok SLC), and UniFlange (Series 1500)

The length of watermain protected with mechanical joint restraint shall be clearly indicated on design and record drawings.

4.4.9 Cathodic Protection

Unless otherwise approved, anodes shall be installed at all valves, tees, caps, elbows, reducers, sleeves, hydrants, curbstops, service saddles and each length of ductile main. The anode shall be connected using the "cadweld" method and shall be installed in accordance with the manufacturer's recommendations and specifications. All "cadwelds" are to be covered with mastik material. The anode shall be connected to curbstops in conjunction with an electrical brass grounding clamp.

In addition, all fitting bolts are to be fitted with 19mm sacrificial zinc caps. Cap shall be

“Protecto-Caps” Cat. No. 175P190 or approved equal.

Anode Sizing Chart for Zinc Anodes

Wtm / Fitting	Anode Size (kg)	Spacing
100mm	2.3	Per length over 3.0m or fitting of similar size
150mm	2.3	Per length over 3.0m or fitting of similar size
200mm	5.5	Per length over 3.0m or fitting of similar size
250mm	5.5	Per length over 3.0m or fitting of similar size
300mm	11	Per length over 3.0m or fitting of similar size
Copper Service	2.3	At each curbstop
Hydrant	5.5	At hydrant base
Valve	5.5	At each valve
Service Saddle	2.3	At each service saddle
Tees, elbows etc.	2.3	On each fitting for 100mm – 150mm pipe
Tees, elbows etc.	5.5	On each fitting for 200mm to 300mm pipe

NOTE: Under certain circumstances, the anode may be connected to the mainstop or a coupling in conjunction with an electrical grounding tailpiece.

4.4.9.1 Anodes

All anodes shall be packaged zinc anodes. The zinc anode coating shall have a 316 stainless steel core wire. The zinc anode casting is to be packaged in cardboard or a cloth bag having a minimum diameter of 100 mm. The backfill material within the package shall be a Gypsum/Sodium Sulphate/Bentonite mixture having an electrical resistivity less than 50 ohm cm wet. An insulated copper (AWG 10-12) wire 3 metres in length shall be brazed to the end of the core wire.

Duratron Systems Limited, Cathodic Technology Ltd., Maple Agencies and Corrosion Service Company Limited presently manufacture anodes to the specified requirements.

4.4.10 Underground Chambers

Underground chambers will be reviewed on a site specific basis. Underground chambers will not be constructed with maintenance-hole frame and grates for access.

4.4.11 Fire Hydrants

Fire hydrants shall be Canada Valve, open left.

Hydrants shall be spaced at a maximum distance of 100 m in residential and 90 m in commercial or industrial areas.

Hydrants shall be located on the projection of side lot lines. A hydrant shall be placed at the end of every cul-de-sac and dead end street as well as at the high points in roads.

All hydrants shall be painted chrome yellow. All hydrants shall have a Flexstake Hydrant Marker Model FHV804, 1.2 m long, colour yellow with a reflective hydrant graphic on both sides at the top of the marker. The required hydrant marker is positioned on the right port as viewed from the street.

A fire hydrant marker shall be installed 0.3m behind each hydrant. The sign shall be reflective with a red hydrant on a white background and measure 0.3 m x 0.3m. The sign shall be mounted 1.5m above grade.

Fire Hydrants require Stortz connections on all steamer ports. Access paths (3.0 m wide) shall be provided to all hydrants where side ditches are required. Provide culverts as required.

Hydrant sets shall be installed at not less than 0.9 m from the centre of the valve to the centre of the hydrant. Tracer wire shall be attached to the outside of the valve box and wire brought into valve box under cap. The tracer wire does not need to be taken to the hydrant.

All owners of private fire hydrants must participate in the Town's "Privately Owned Fire Hydrant Maintenance Program" (Form #D001). A yearly fee will be charged for this service

4.4.12 Valves

Isolation valves shall be resilient seat gate valves with mechanical joints, open left, Clow or Mueller. Valve boxes shall be 5-SL-48 sliding or Mueller MVB composite complete with guide plate and ductile adjustable top and lid or approved equal with cap painted blue.

Generally, isolation valves shall be located on the projection of side lot lines at or near intersections as required for spacing. Generally 3 valves shall be placed at cross intersections and 2 valves at tee intersections. An isolation valve shall be installed between each fire hydrant such that no two adjacent fire hydrants are out of service.

Where watermains are terminated pending future extension, a valve and 2 additional lengths of watermain with plug, blow-off and thrust block shall be installed.

Valves shall have a maximum spacing of 100 m for distribution watermains and 400 m for trunk supply mains.

Any valves placed in gravel shoulders or roundings shall be protected with asphalt or concrete apron.

4.4.13 Air Release and Drain Chambers

Air release valves shall be utilized at high points of all watermains where there is no servicing or fire hydrants to provide air release or as requested by the Town Engineer.

Drains shall be provided at low points of all watermains 350 mm and larger.

4.4.14 Service Connections

Service connections shall be 19mm type K copper pipe, Rehau's Municplex (blue) or Series 160 PE and shall terminate at 2.5 m left of sanitary connection (when facing lot) and supplied with a 89 mm x 38 mm marker from the invert of the service to 600 mm above grade painted blue.

Service connections shall be left with a tail up to grade and capped or crimped.

Service connections for industrial, commercial, institutional or multiple dwelling use will be considered on an individual basis. Fire connections may be required for industrial, commercial, institutional or multiple dwelling lots.

Water service fittings shall be as follows:

Main stop ■ Mueller H25008
Curb stop ■ Mueller H25209
Service Saddle ■ Robar 2706 double strap
Tapping Saddle ■ Robar 6906
Service Boxes ■ Mueller A-726
Stainless Steel Rod

4.4.16 Metering

All services shall be metered including irrigation and other exterior uses. Meters to be Neptune T-10, complete with radio read.

For larger installations it is necessary to install a meter in accordance with the "Canadian Standards Association, B64.10-01 – Manual for the Selection and Installation of Backflow Prevention Devices/Manual for the Maintenance and Field Testing of Backflow Prevention Devices".

4.4.17 Tracer Wire

Tracer wire to be 10 gauge, multi-strand shall be placed on top and attached in two places on each length of P.V.C. watermain. All connections shall be made with "Dryconn Waterproof Connectors" or approved equal.

4.4.18 Requirement for Looping

To all degrees reasonable, watermains shall be looped to the satisfaction of the Town Engineer. An alternative to be considered with the approval of Town Engineer, is the installation of an automatic flushing station.

4.4.19 Testing and Acceptance

The complete water system including service connections to the property line and hydrants shall be tested in accordance with the Town's Watermain Commissioning Protocol available on the Town's website at www.thebluemountains.ca

4.5 Roadways

4.5.1 Road Works

Asphalt roadways complete with concrete curbs and gutters designed and constructed in accordance with the most recent requirements and specifications of the Town, OPSS and OPSD are required on all road allowances within a plan of subdivision. The geometric standard of the roadway shall be as stipulated in the Town's Engineering Standards and Drawings and designated by the Town. The balance of the road allowance not occupied by the roadway, driveways, or sidewalks shall be graded and completely top soiled and sodded or hydro-seeded to the satisfaction of the Town.

Roadways with a rural, open ditch, cross section will only be considered in deferred rural areas where groundwater levels are proven to be well below proposed ditch grade and shall not be provided unless approved by the Town.

4.5.2 Classification

All roadways shall be classified according to the traffic volume expected and to the intended use of the roadway. For predominantly residential areas, the classifications shall be as follows:

- Cottage Lane (< 50 vehicles per day)
- Local – Rural
- Local – Urban
- Collector – Minor
- Collector – Major
- Arterial

For industrial and commercial areas the roads shall be classified as Local or Collector dependent on the length of street, traffic volume expected and amount of truck traffic.

4.5.3 Geometric Design Elements

Road Allowance Widths

Geometric Detail	Cottage Lane	Local		Collector		Arterial
		Rural	Urban	Minor	Major	
Min R.O.W.	20	20	20	20	26	30
Design Speed	50	50	50	60	60	60
Min. Safe Stop Distance	65	65	65	85	85	85
Min. K Value (Sag)	12	12	12	18	18	18
Min. K Value (Crest)	8	8	8	15	15	15
Min. Horizontal Radius	80	80	80	180	180	180
Pavement Width	4.0m with 1.0m shoulders	6.0m with 1.5m shoulders	8.5	10	14	14
Pavement Crossfall (%)	2	2	2	2	2	2
Top Course Asphalt (HL3)		40	40	50	50	50
Bottom Course Asphalt (HL4)		40	40	50	50	50
Granular A	150	150	150	150	200	200
Granular B	300	450	450	450	450	450
Min. Grade (%)	0.5	0.5	0.5	0.5	0.5	0.5
Max. Grade (%)	10	8	8	6	6	6
Max. Grade for through roads at intersections (%)	3.5	3.5	3.5	3.0	3.0	2.0
Max. Grade for stop roads at intersections (%)	2.0	2.0	2.0	2.0	1.5	1.0
Intersection Angle (degrees)	80-90	80-90	80-90	80-90	80-90	80-90
Min. Tangent Length between reverse curves	30	30	30	50	60	130

A 3m x 3m permanent easements may be required on lots off the R.O.W., subject to Ontario Hydro layout.

4.5.4 Horizontal Curve

Centreline radii less than 80 m will not be accepted.

In general “right angle bends” will not be permitted on local streets except in the case of “Courts” or “Crescents” servicing no more than 50 residential units. Where permitted, these bends must not have a deflection angle greater than 110 degrees, have a minimum inside curb radius of 15 m and must be designed with an expanded bulb.

4.5.5 Vertical Alignment

All grades shall be referenced to edge of pavement or lip of gutter and referenced to geodetic datum. Longitudinal roadway grades shall conform to Table 4.5.2

Table 4.5.2 Minimum and Maximum Road Grades

Roadway Classification	Grade (%)		
	Minimum	Desirable Maximum	Maximum
Cottage Lane	0.5	6.0	8.0
Local – Rural	0.5	6.0	8.0
Local – Urban	0.5	6.0	8.0
Collector - Minor	0.5	6.0	8.0
Collector - Major	0.5	5.0	6.0
Arterial	0.5	4.0	6.0

Cul-de-sac and expanded bulb corners shall be designed with the centreline profile increased to ensure that a minimum lip of gutter grade of 0.5% is maintained along the full length of the lip of gutter, to account for length increases due to curvature.

The minimum grade of the curb return at corner curves shall be increased to 0.6% where drainage is not intercepted by either storm sewer inlet or surface conveyance to an approved drainage system.

4.5.6 Vertical Curves

All points of grade change in excess of 1% shall be designed with vertical curves. The minimum visibility curves to be used are outlined in Table 4.5.3. The minimum tangent length of any road grade shall be 9.0 m.

Minimum K Values

Classification or Design Speed	K	
	Crest VC Min Stopping Site Distance	Sag VC Headlight Control
Lane / Local	7	12
Collector	7	12
50 km/hr	7	12
60 km/hr	15	20
70 km/hr	22	25
80 km/hr	35	30

The minimum length of vertical curve is 30 m except for:

- Smoothing vertical curves for super-elevation runoff and tangent runout, which can be reduced to 15 m and 20 m respectively,
- Adverse design conditions, reduced lengths may be permitted.

In the vicinity of sag vertical curves, the cross slope shall be adjusted as necessary to maintain a minimum lip of gutter grade of 0.5% to the lowpoint.

4.5.7 Super-elevation

Super-elevation is required on Collector and Arterial Roadways with a design speed of 50 km/hr and over and is to conform to the guidelines in the TAC Manual.

4.5.8 Intersections

Roadways should be designed to intersect at right angle, however, roadways may intersect at angle up to 80° and such angle should be maintained for a minimum distance of 40 m.

Intersections on curves are to be avoided. Where intersections must be placed on a curve, calculations and drawings must be submitted confirming the adequacy of intersection sight distance requirements in the TAC manual.

4.5.8 Fire Routes

All public and private roadways shall conform to the Town's Fire Route By-law, 2001-88.

4.5.9 Intersection Spacing

Intersections should be spaced a minimum of 60 m apart on local and collector roads and 80 m apart on arterial roads.

4.5.10 Intersection Sight Distance

Intersections shall be designed with sufficient sight distances for design vehicles to depart from a stopped position and make the desired manoeuvre through the intersection.

4.5.11 Backfall at Intersecting Streets

At all street intersections the normal crossfall of the major street shall not be interrupted by the crown line of the minor street. A 1% or 2% backfall shall be provided on the minor street at all street intersections. This backfall shall continue to the end of the curb return radii to facilitate proper drainage of the intersection. Overland flow routing of storm drainage through the intersection must be maintained.

4.5.12 Curb Return Radii at Intersections

The curb return radii at street intersections shall conform to the following dimensions:

Pavement width Street A	Pavement width Street B	Curb Return Radii
8.5 m	8.5 m	10.0 m
8.5 m	10.0 m	10.0 m
8.5 m	12.8 m	10.0 m

4.5.13 Cul-De-Sacs

Cul-de-sacs will be permitted on dead-ended low volume local roadways only, provided that the number of dwellings units developed on the cul-de-sac does not exceed 40 units and the length of the cul-de-sac measured from the centerline of the intersecting street to the centre of the cul-de-sac bulb does not exceed 250 m. The length of the Cul-de-sac can be increased to 500 m with a maximum of 80 dwelling units if a secondary access restricted to emergency use is located within 85 m of the end of the bulb connecting the cul-de-sac with another municipal roadway or lane.

Cul-de-sac bulbs on local residential roadways shall have an 20 m radius road allowance and shall be designed with a minimum lip of gutter (edge of pavement) radius of 15 m and a 25 m curb return measured at lip of gutter (edge of pavement).

Geometric requirements for cul-de-sacs shall apply for both symmetrical and offset bulbs.

Islands will not be approved inside cul-de-sacs.

Cul-de-sac egress longitudinal road grades shall not exceed +4% and shall be from centre bulb to intersecting roadway.

4.5.14 P-Loops

The centerline length of a looped local roadway with a single entrance from an intersecting main local or collector standard roadway shall not exceed 850 m nor service more than 85 dwelling units or the equivalent commercial or industrial properties.

The centre line length of the primary leg of a P-loop shall not exceed 180 m. Centre line lengths shall be measured between centre line intersections of connecting roadways.

All single entry looped local roadways in excess of the above limitations shall be provided with a secondary access restricted to emergency use connecting the internal loop to another municipal roadway or lane.

Islands may be approved inside P-Loops provided that the island is constructed with an acceptable hard surfacing or landscaped to the satisfaction of the Town.

4.5.15 Single Access Developments

The maximum number of residential units or equivalent commercial or industrial properties that may be constructed with a single access is 85.

With a secondary access for emergency conditions, the maximum number of residential units or equivalent commercial or industrial properties that may be constructed with a single access is 150.

4.5.16 Secondary Access Design Criteria

Where secondary accesses are required to single entrance developments for emergency conditions, they shall be:

- 3.5 m wide centred within a minimum 6.0 m right of way provided there are no obstructions or curves
- the traveled surface shall be asphalt, concrete, paving stone or turf stone or approved alternate
- capable of supporting firefighting equipment
- designed with adequate radii, width, horizontal and vertical alignments as that required for fire routes under the Ontario Building Code.
- provided with a removable gate or barrier pre-approved by the Town.

4.5.17 Driveway Entrances

All new residential driveways shall be paved with 65 mm HL3A from curb to the property line on a base of a minimum of 200 mm Granular 'A'.

The minimum clear distance between the edge of driveway and a utility structure or hydrant shall be 1.5 m.

The minimum setback from lot line shall equal the "Exterior Side Yard, Minimum" for the applicable use in conformance with the Zoning By-Law.

Rural driveways shall include an entrance culvert unless the driveway is sited at a ditch highpoint. The maximum length of culvert is 10.0 m.

The maximum width of an urban driveway curb cut shall be 6.0 m and 4.0 m driveway width.

The minimum allowable design grade of any residential driveway shall be 2%. Driveway grades shall be away from the building and the use of reverse grade driveways is not permitted.

The maximum allowable design grade of any portion of driveway on municipal lands shall be 4% and on private lands, the maximum grade may be increased to 6%.

4.5.18 Special Road Designs

Special road designs, which are not covered by The Blue Mountains Engineering Standards, shall be in accordance with the most recent provisions of the geometric design standards manual and urban street geometrics, as adopted by the Municipal Engineers Association. Special designs may be required in high density residential, commercial and industrial areas. Consideration of special designs must be pre-approved by the Town's Engineer.

4.5.19 Pavement Design (Roadways)

Pavement design shall be completed by the geotechnical consultant in accordance with the most recent The Blue Mountains Engineering Standards, OPSS and OPSD.

Tests of sub-grade materials must be conducted by a certified soils laboratory and be acceptable to the Town. Copies of tests, along with proposed road designs, shall be submitted to the Town. Minimum thickness of asphalt and granular material shall be as indicated on Town Standard Drawings in all cases.

4.5.20 Top Course Asphalt

Approval to place top course asphalt is required from the Town's Engineer. The following must be completed:

- all sidewalk, curb and boulevard work;
- raise maintenance hole and catchbasin frames;
- raise water valve box
- flush and sweep surface and evenly apply tack coat;
- base course asphalt pad as required in accordance with OPSS;
- sewer video inspection and acceptance by the Town;

Place top course asphalt in accordance with OPSS;

4.5.21 Curbs and Gutters

Minimum grade on curb is 0.75% desirable, 0.5% minimum.

The Town, at its sole discretion, may require barrier, mountable or semi-mountable curbs.

Prior to final acceptance of curb and gutter, all blemishes shall be rectified by removing a minimum 1m section of curb and replacing.

4.6 Street Name and Traffic Signs

4.6.1 Traffic Control Plan

The Traffic Control plan shall show the proposed location of signs to be installed in the subdivision. The plan shall be part of the engineering drawings, which must be approved by the Town.

4.6.2 Street Name Signs

Street name signs shall be placed at every intersection and shall be double sided.

Street names shall be approved by the Town.

Signs are to be aluminum, anodized both sides, according to the following requirements:

Sizes	Material
600 mm -	1.6 mm utility series
600 mm – 900 mm -	2.0 mm No. 655T6
over 900 mm -	3.2 mm No. 655T6

4.6.3 Traffic Control Signs

Temporary regulatory signs must be reflective. All permanent signs must be to Town Standard.

Traffic control signs shall be erected upon completion of road base granular.

Traffic control signs shall conform to the most recent versions of the Ontario Traffic Manuals or the Highway Traffic Act Regulations for Ontario.

All traffic control signs are to be made with high intensity type reflective sheeting approved by the Ministry of Transportation Ontario, the current version of the Ontario Traffic Manuals and the Town's Engineer, including colours.

4.7 Roadway Markings

The Consultant shall design pavement markings for all roadways over two lanes in width or as required by the Town. The design shall be in accordance with the Ontario Traffic Manual and approved by the Town's Engineer. These pavement markings will be installed on the top coat of asphalt and, in some circumstances at the discretion of the Town Engineer, on the base coat of asphalt.

All roadway markings shall be installed in accordance with OPSS 532.

4.8 Traffic Signals

Traffic Signals are to be designed on individual site-specific bases and shall include emergency vehicle pre-emption detector equipment.

4.9 Street/Site Lighting

The minimum standard for street lighting shall be 70 W HPS set on 9 m sectional steel poles. Each light must be controlled by a dusk to dawn photoelectric cell. Power feed shall be completely underground. The lights shall generally be placed on the south or east side of the road. Particular care shall be taken to adequately illuminate the intersections. Under no circumstances shall street light poles be located in the front slope or centreline of ditches. Architectural style luminaries and poles will be considered on a case by case basis. The Town reserves the right to limit the number of alternative styles and types within the Town.

4.9.1 Lighting Levels and Uniformity Ratio

Lighting shall be supplied and installed on all streets, pedestrian walkways and areas of common use.

Road Classification	ROW / Pavement Width	Average Illumination Level	Max to Avg Uniformity Ratio
Residential	20 m/8.5 m	2 Lux	6:1
Urban Collector	26 m/14.5 m or 8.5 m	6 Lux	3:1
Minor Arterial, Major Collector	30 m/16.0 m	9 Lux	3:1
Walkways		2 Lux	6:1

All lighting shall be designed such that light pollution is minimized. If required by the Town, the Consultant shall submit an Illumination Study prepared by a qualified engineer addressing light pollution abatement and/or photometric design calculations demonstrating average illumination and uniformity ratio achieved.

4.9.2 Light Source

The light source shall be High Pressure Sodium or for certain applications and with site specific approval, metal halide. Minimum wattage of lights shall be 70 watts and all intersections must have a light located at the intersection with 100 watts.

4.10 Residential Lot Drainage And Sodding

4.10.1 General

All lot drainage shall conform to the Stormwater Management Report, Standard Practice Policy Bulletin P:02-01 and Town Engineering Standards.

The Consultant shall be responsible for approval and certification of the design and final grading for each lot at time of building permit application to the satisfaction of the Chief Building Official.

4.10.2 Lot Grading Criteria

Lot grading shall provide for the following:

- rear to front lot grading is permitted except in areas of high groundwater levels. A maximum of three rear lots shall outlet between any two lots;
- rear lot catchbasins shall be eliminated wherever possible;
- maximum number of lots drained by a rear lot CB shall be 5;
- where several lots drain through a swale to a rear lot catchbasin on private property, a 3m wide easement shall be provided for the drainage swale in favour of the serviced lots and a 4m wide easement for the CB and lead in favour of the Town;
- where rear lot catchbasins are used, all buildings shall be protected from flooding if the inlet is blocked or surcharged by a major storm event;
- maximum ponding depth for drainage swales is 0.35 m.
- minimum slope for swales shall be 2.0%;
- swale profile shall be 3:1 or flatter
- a minimum of 3 of the rear yards shall be graded at 2% - 5% slope;
- each lot shall have at least one side yard with a maximum slope of 2% for 1.0m continuous width from front to rear yard;
- maximum slope between houses shall be 4:1;
- driveways shall have minimum 2% and maximum 6% slope (on the apron);
- no part of the driveway shall slope greater than 4% on the Town right of way;
- grade around houses shall be a minimum of 2% away from houses from a point 200 mm below top of foundation wall or as required by OBC.
- Finish grade tolerance is 50 mm at lot corners, grade change points, spot grades, etc
- Finish grade tolerance is 25 mm in swales and ditches

4.10.3 Retaining Walls

Retaining walls shall be constructed according to the following:

- the wall and tie-back shall not come closer to the property line than 300mm;
- retaining wall design and construction shall be approved by the Town's Engineer, the Building Department and may require a building permit in accordance with Section 2

of the OBC;

- privately owned retaining walls shall be constructed solely on private property;
- Non-climbable fencing or equal shall be installed at the top of the wall if height excess is 0.6 m.

4.10.4 Rough Grading

Prior to the issuance of any certificates by the Town accepting the Works, lots shall be rough graded to the below tolerances.

- Achieve positive drainage to the satisfaction of the Town Engineer;
- Lot corners, grade changes and spot elevations: 300mm;
- Swales and ditches, except side yard swales, without finishing topsoil: 100mm

4.11 Block Grading

4.11.1 General

All block grading shall conform to the Storm Water Management Report.

The Consultant shall be responsible for approval and certification of the design and final grading for each block at time of building permit application to the satisfaction of the Chief Building Official.

4.11.2 Block Grading Criteria

The criteria for block grading are as follows:

- where catchbasins are used for block drainage all buildings and structures shall be protected from storm water if the inlet is blocked or surcharged by a major storm event;
- where block drainage is surcharged to an existing overland flow route, the route shall be protected from erosion;
- no more than 5% of the block surface area shall drain directly onto the abutting road allowance;
- minimum slope for swales shall be 2%;
- maximum ponding depth for swales shall be 0.35 m.

4.11.3 Ground Cover

The requirement for block ground cover is as follows:

- all blocks shall be sodded using 100 mm topsoil and No. 1 nursery sod for 5 m width around their perimeter when base course asphalt is placed on roadways, the remainder of the block shall be at minimum seeded using 100 mm topsoil, with seed

- of the quality and quantity approved by the Town, and mulch;
- all swales and drainage easements shall be sodded using 100 mm topsoil and staked No. 1 nursery sod;
- All slopes greater than 10% shall be protected from erosion.

4.11.4 Rough Grading

Prior to the issuance of any certificates by the Town accepting the Works, blocks shall be rough graded to the below tolerances.

- Achieve positive drainage to the satisfaction of the Town Engineer;
- Lot corners, grade changes and spot elevations: 300 mm;
- Swales and ditches, except side yard swales, without finishing topsoil: 150 mm

4.12 Erosion and Sediment Control

4.12.1 General

All erosion and sediment controls are temporary measures constructed prior to any other site work and shall be maintained until any disturbed areas are stabilized and approved for removal by the Town.

All erosion and sediment control measures shall be inspected by the Consultant once per week and after each rainfall of 10 mm or greater. Inspection reports shall be forwarded to the Town's Engineer within 5 days of inspection.

Erosion and sediment control measures shall be designed in accordance with Provincial guidelines.

4.12.2 Catchbasin Sediment Control

All catchbasins shall be provided with sediment control during construction activities and shall be maintained until any disturbed areas are stabilized and approved for removal by the Town.

4.12.3 Stone Mud Pad Construction Entrance

In order to reduce the tracking of mud onto paved streets, a pad of crushed stone shall be constructed at the site entrance and exit leading onto any existing road. The stone pad shall be a minimum of 450 mm thick, 35 m long and 7 m wide. The first 5 m from the property line shall be constructed with Granular 'A'. The next 15 m shall be 50 mm clear stone and the remaining 15 m shall be constructed with 150 mm rip rap.

This stone mud pad must be maintained as required given the site conditions to ensure there is no mud tracking on the municipal roads. The Town's Engineer may direct additional measures

to be taken to eliminate mud tracking up to and including vehicle washing prior to exiting the site.

In some cases the drawings shall specify a required truck hall route.

4.13 Utilities

The appropriate utility company, or their approved contractor, shall install the services for Bell, Hydro, Gas, Cable TV. Utility crossings for new roads shall be placed prior to placement of granular road base material. Utility crossings for existing roads shall have the asphalt surface saw cut and removed for a width of the trench plus a minimum of 0.5 m out from each side of the trench walls. Minimum depth of bury for utilities is 0.9 m, unless otherwise approved by the Town's Engineer.

Utilities installation shall require full time engineering supervision to be approved by the Town's Engineer.

Compaction of backfill for utility trenches shall be 95% Standard Proctor Dry Density.

4.14 Canada Post

The Consultant must communicate directly with Canada Post for locating of their proposed facilities. All proposed locations must be shown on the Composite Utility Plan. Any temporary placement of post boxes must be placed in accordance with the approved final location.

4.15 Landscaping

4.15.1 General Streetscape Standards

Streetscaping will be considered on a site-specific basis.

4.15.2 Standards and Guidelines for Naturalization Areas

All disturbed natural open-space blocks and lands adjacent to conservation areas, as well as the lands surrounding stormwater management facilities, are to be re-vegetated using naturalizing plant materials. The planting design must employ native plants using a variety of trees shrubs and ground covers to re-establish the local ecosystem. If the site had been previously disturbed, landscape restoration strategies must be employed to reinstate a naturalized landscape condition.

4.15.3 Notes for Naturalization Submission Drawings

The following layout note is to be included on the submission drawings for all areas to be naturalized:

All plantings and hard landscape features are to be staked out on site and approved by the Landscape Architect and **Town's Engineer** prior to installation. Any deviations from the approved landscape plans require prior Town approval.

5 GEOTECHNICAL

5.1 Geotechnical Report

When a Geotechnical Report is required for a project, the Geotechnical Engineering Consultant shall prepare a report on the existing soil conditions which shall include, but not be limited to, the following:

- The identification, description and limits of the existing soil regimes, including the extent of topsoil and its suitability for reuse;
- Suitability of native materials for trench backfill;
- The conditions under which the native material may be used as trench backfill;
- The procedures to be used for high moisture contents and water table levels which may affect the proposed servicing or structural works of the concerned area and surrounding lands;
- The extent of native material which is unsuitable for trench backfill and the procedure for dealing with it such that it will not affect the structural stability of the proposed municipal services;
- Areas and procedures to be followed where blasting may be required with due consideration to surrounding structures and services;
- The minimum road material depths for granular and pavement design;
- Any special recommendation for bedding materials;
- Potential corrosive or chemical problems that may affect services or structures (e.g. high sulphates) and the method of resolving such problems;
- Potential corrosively related to the installation of watermain and appurtenances;
- Recommendations in dealing with filling conditions within the road allowances, on building lands, in the construction of berms etc;
- Identify problem areas and recommend mitigating procedures regarding the stability of existing slopes and the extent of unstable soils or conditions.
- Any special recommendations to be followed in the design and construction of building foundations.
- The engineering properties of the native material including frost susceptibility, natural moisture content, compaction characteristics, relative density and structural integrity.
- Recommendations in achieving proper compaction.
- Recommendations in dealing with deep excavation of trenches.
- Recommendations in dealing with septic or well systems that may be affected by the proposed building and servicing works.

The report is to confirm that sufficient boreholes have been taken to establish definite requirements and recommendations for the servicing and building works. General Soils Report must identify minimum bearing capacity of the native soil (i.e. 75 kPa) preferably on a hole by hole basis. Boreholes located in the area of proposed underground municipal services are to be taken to a depth of at least one (1) meter below the deepest trench.

Requirements and recommendations contained within this report along with borehole logs and grain size analysis of the native soils are to be incorporated by the Consultant into the first submission to the Town. Any such requirements and recommendations that are not so incorporated are to be drawn to the Town's attention with specific reasons.

5.2 Geotechnical Engineering Inspection

The General Consultant must have their own site representative on site during any grading and/or construction works.

The Geotechnical Consultant must ensure that OPSS 514 regarding backfilling and compaction within road allowances and lots where fill exceeds 1.0m in thickness is strictly adhered to. The Geotechnical Consultant's certification must make reference to this specification.

During construction, the Geotechnical Consultant shall supervise the installation of bedding or embedment and the backfilling of all trenches within road allowances and easements. A trench backfill certification is required to indicate that sufficient tests have been carried out to obtain a representative report as to the compaction of the backfill and they find the backfill to be in compliance with Town Specifications and requirements.

A final subgrade certification is to confirm that the final subgrade conditions are equal to or better than those anticipated in the preparation of the pavement design. If these conditions are less than what was anticipated, the owner and the Town are to be immediately advised with a new pavement design recommendation.

Where grading operations require the placement of "engineered fill" the Geotechnical Engineer must certify that the fill located at 1.0m below finished grade and deeper has been sufficiently compacted to assure a minimum bearing capacity of 75 kPa and a 98% Standard Proctor Density.

The material testing of any major structure, as determined by the Town, is to be carried out by an independent testing firm pre-approved by the Town. Such testing is to be carried out in accordance with the latest revision of the O.P.S.S. and C.S.A. requirements. All test results are to be forwarded to the Consultant, and the Town, with the appropriate comments and recommendations. Upon completion of the material testing, the testing firm is to certify to the owner and the Town that the material requirements for the concerned structure have been achieved.

6 REQUIREMENTS FOR TOWN GARBAGE/RECYCLING COLLECTION

In order to quantify for Town garbage/recycling collection services, new developments or redevelopments (buildings) must adhere to the requirements outlined in By-law #2003-16 Solid Waste Collection, including amendment #2004-24 and any subsequent amendments, and other associated documents. It should be noted that these are general requirements only and the Town reserves the right to enact additional requirements during detailed review of specific projects. The Town will review each development or redevelopment individually and ultimately reserves the right to designate the type of collection, access and storage required.

Developments and redevelopments that meet the Town's eligibility requirements must provide the required facilities which allow for municipal collection of garbage and recyclable materials. If the facilities cannot, as determined by the Town, be provided, the requirements will be listed in the legal documentation concerning the development and notice given to all future owners of the need to provide and maintain private collection service until such requirements are met.

All municipal collection services are subject to the conditions required by the applicable By-laws.

To ensure the Town has the opportunity to review site plans as they pertain to garbage/recycling collection, applications must include details on:

- access routes;
- loading facilities;
- garbage rooms/storage facilities;
- recycling rooms/storage facilities;
- size and number of garbage containers to be used; and
- number of dwelling units in the development/total ground floor area/number of stories.

Failure to comply with these guidelines and any additional requirements imposed by the Town will result in collection services not being approved or suspension of collection services.

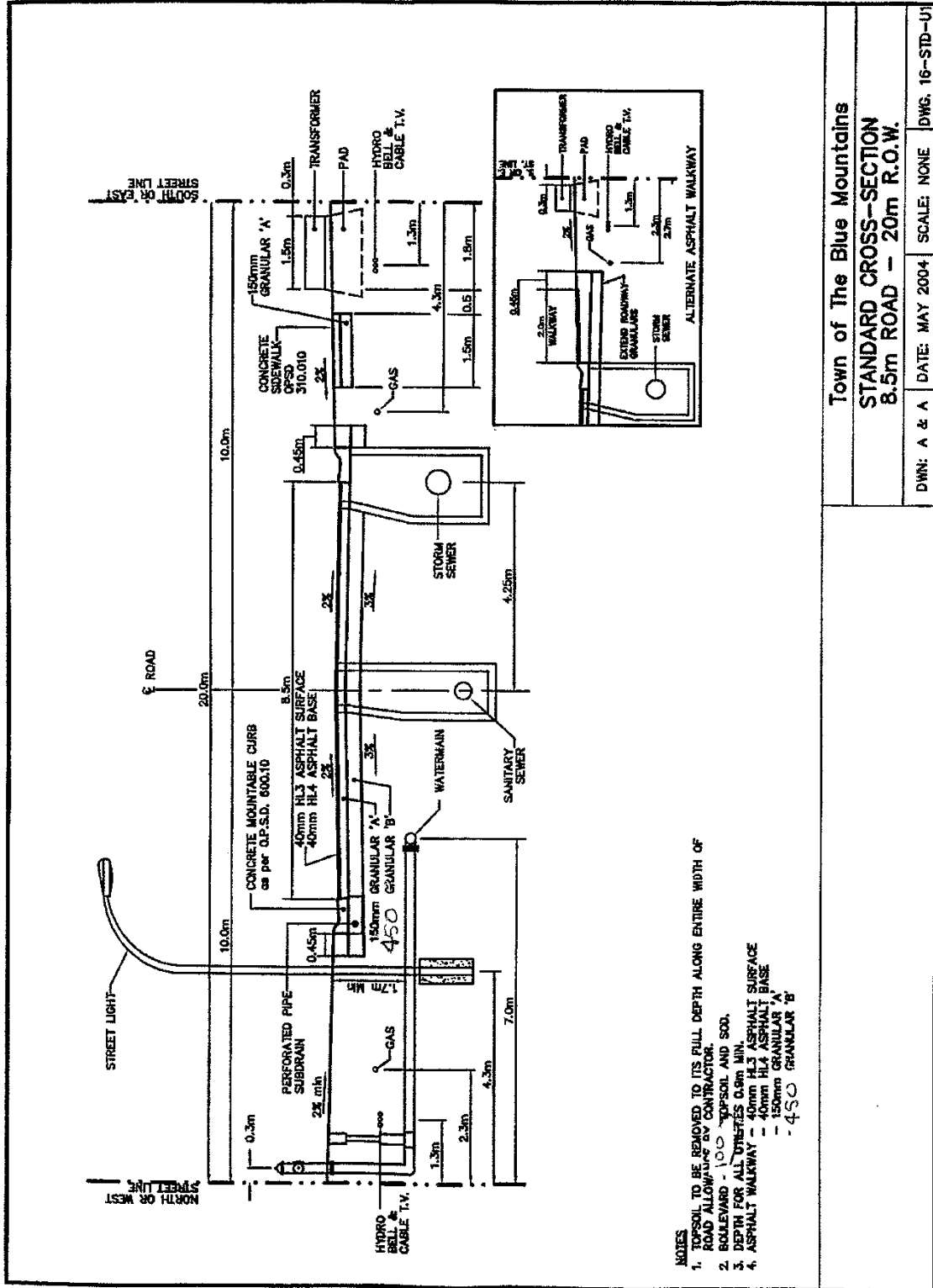

Town of The Blue Mountains
 STANDARD CROSS-SECTION
 8.5m ROAD - 20m R.O.W.

DWN: A & A DATE: MAY 2004 SCALE: NONE DWG. 16-STD-U1

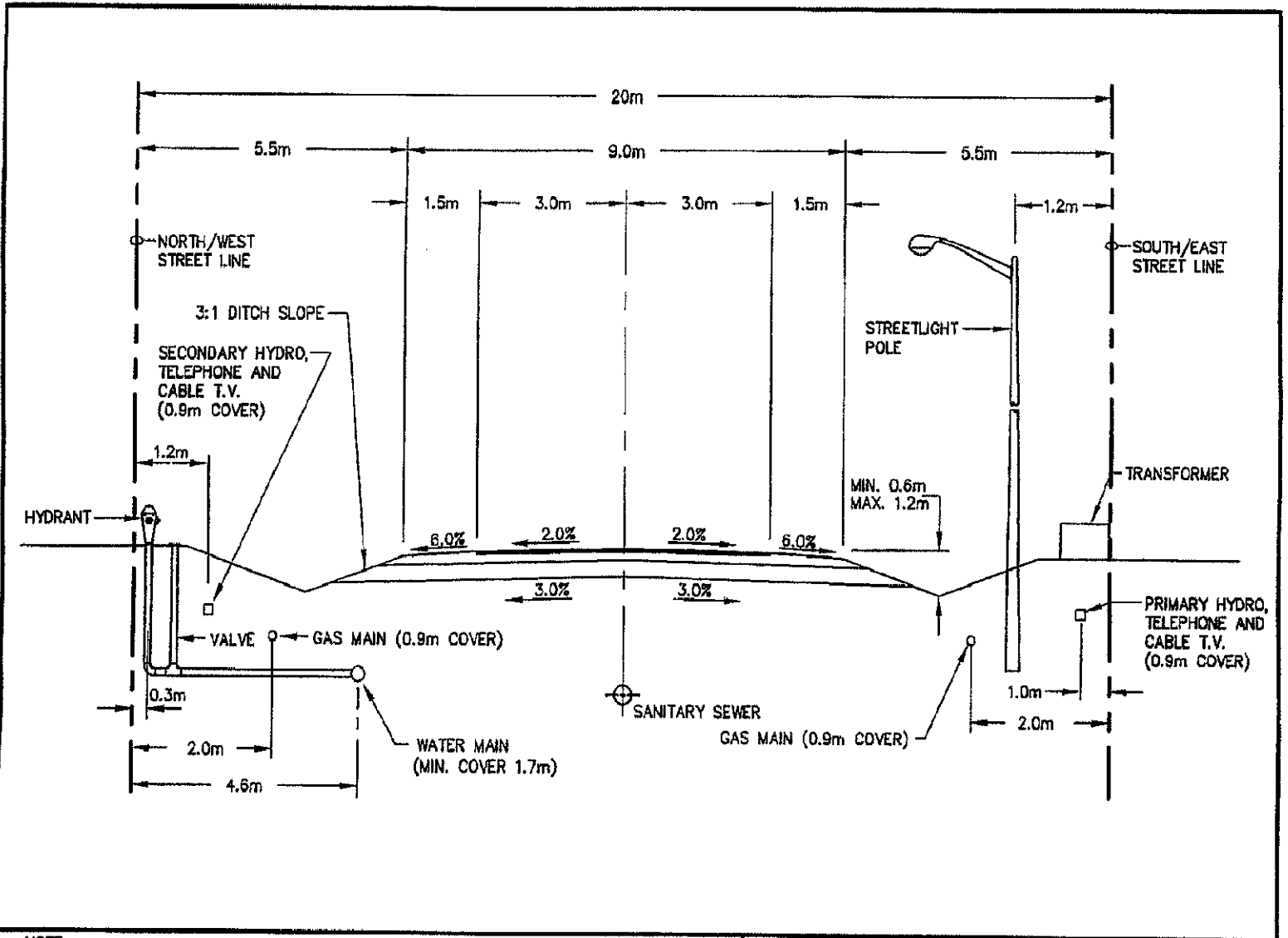

NOTE:
 ROAD - 40mm HL3 SURFACE COURSE ASPHALT
 - 40mm HL4 BASE COURSE ASPHALT
 - 150mm GRANULAR 'A'
 - 4-50 GRANULAR 'B' OR 'C'
 BOULEVARD - 100 TOPSOIL AND NURSERY SOD

Town of The Blue Mountains			
RURAL STANDARD CROSS-SECTION			
9.0m ROAD - 20m R.O.W.			
DWN: A & A	DATE: FEB. 1998	SCALE: NONE	DWG. No. 16-STD-R2

OWEN SOUND INTENSITY DURATION FREQUENCY VALUES

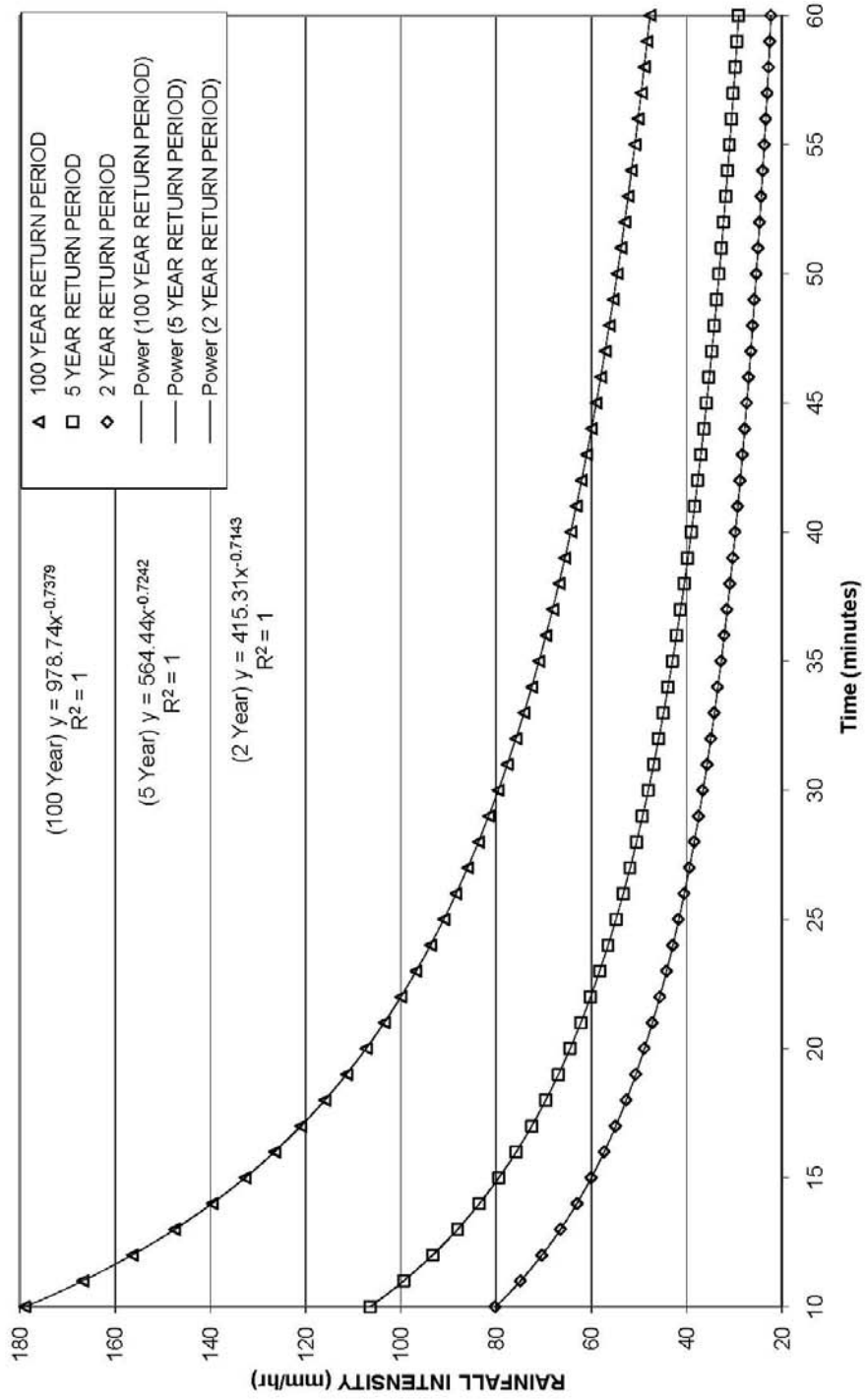

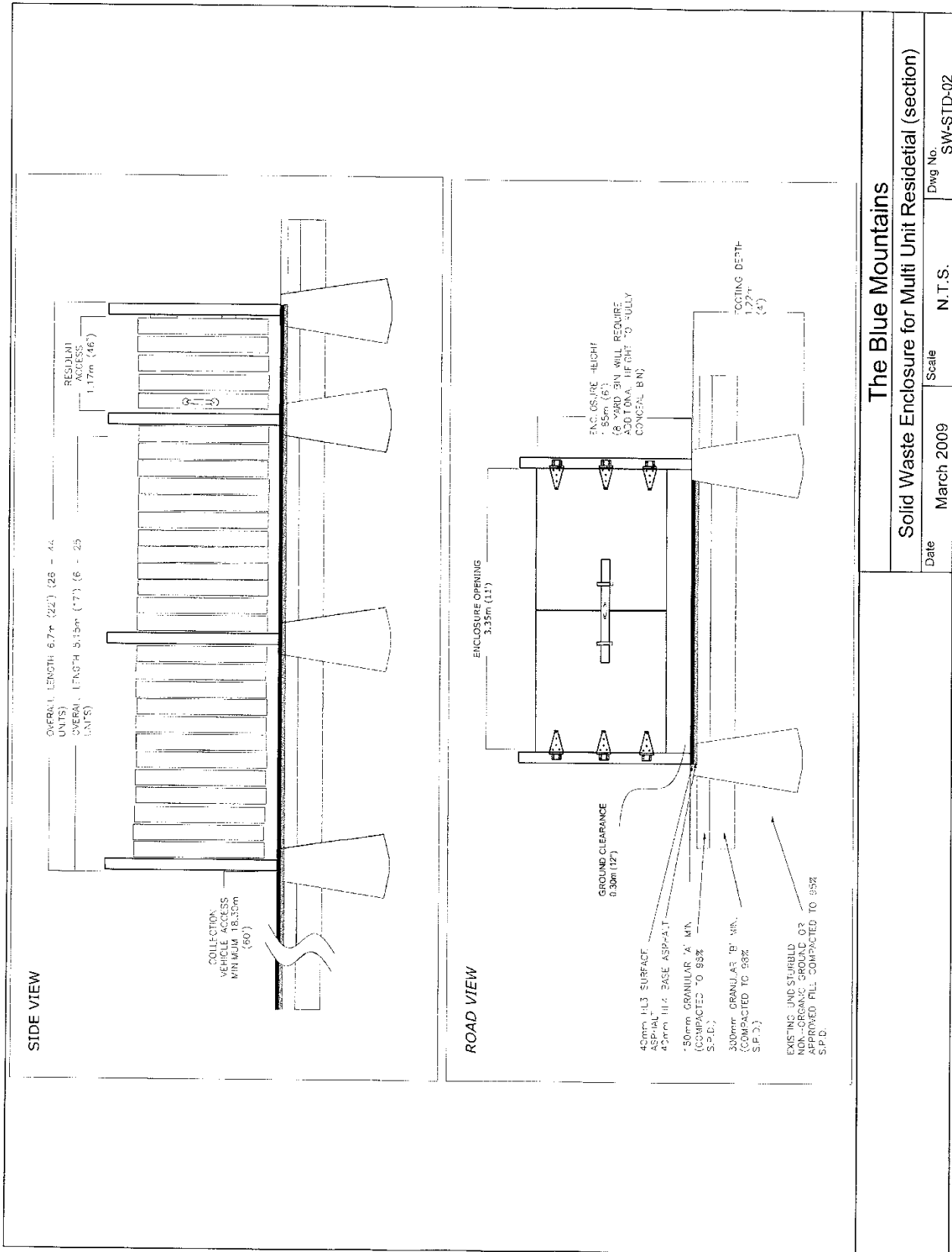

The Blue Mountains		Dwg No.	SM-STD-02
Solid Waste Enclosure for Multi Unit Residential (section)		Scale	N.T.S.
Date	March 2009		

REV.	ALTERATION	DATE	BY

KING U.S. ORDER NO.:	KING CAN. ORDER NO.:
CUSTOMER ORDER NO.:	

SPECIFICATIONS
 CATALOGUE NO.: K829-HCSH-III-100(MOG)
 -HFS-120-KPL10-PBC

QUANTITY: HYDROFORM GLASS SHALLOW LENS
IES LTG. CLASS.: TYPE III
WATTAGE: 100W
SOCKET SIZE: MOGUL
LIGHT SOURCE: HIGH PRESSURE SODIUM
LINE VOLTAGE: 120V
PAINT: BLACK
ANSI 554 LAMP BY OTHERS

BALLAST SPECIFICATIONS
SUPPLIED ALTERNATE
 BALLAST TYPE: HX-HPF HX-HPF
 BALLAST MANU.: UNIVERSAL ADVANCE
 CATALOG NUMBER: S100MLTC3M 71A8091

OPTIONS:
 QUICK DISCONNECT
 TERMINAL BLOCK
 OTHER: KPL10 LEVELING DEVICE
 PHOTO BUTTON CELL

FOR WIRING DIAGRAM SEE
 DRAWING 209B0207

CUSTOMER APPROVAL:
KING LUMINAIRE
640 WALTON'S LANE, P.O. BOX 7, CAMDEN, ONTARIO, CANADA L7R 3M8
 TEL: 519-836-1100 FAX: 519-836-1101
 1153 WYKE AVENUE, ONT. CAN. TEL: 519-836-1107

DRAWING NAME:	DATE:	DWG BY:	REV.
APPROVAL DWG	8927-3	10/2/06	M.L.
PROJECT/CUSTOMER:			

VIC-000001/06071

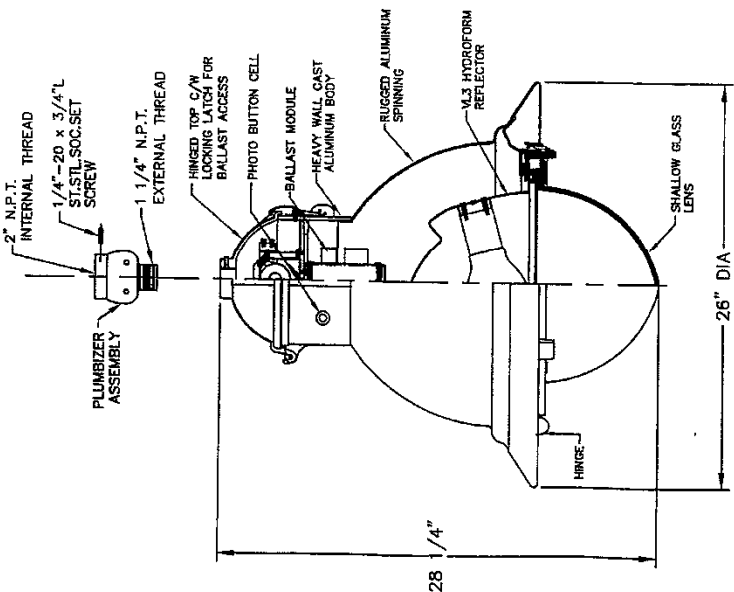

- NOTE:**
- 1) LAMP BY OTHERS
 - 2) UNDERSIDE OF SPINNING TO BE PAINTED SAME COLOR AS REST OF LUMINAIRE
 - 3) PIPE SEALER TO BE USED ON ALL N.P.T. THREADED COMPONENTS

PART	REVISION
GLOBE	
CAPITAL	
OPTICS	
BALLAST	
FINIAL	
OTHERS	

PLANT REFERENCE DWG. # 5

CERT. I.D. CS ET

The Blue Mountains

Street Lighting Fixture Style B

Date	Scale	Dwg No.
March 2009	N.T.S.	LT-STD-B-FIXTURE

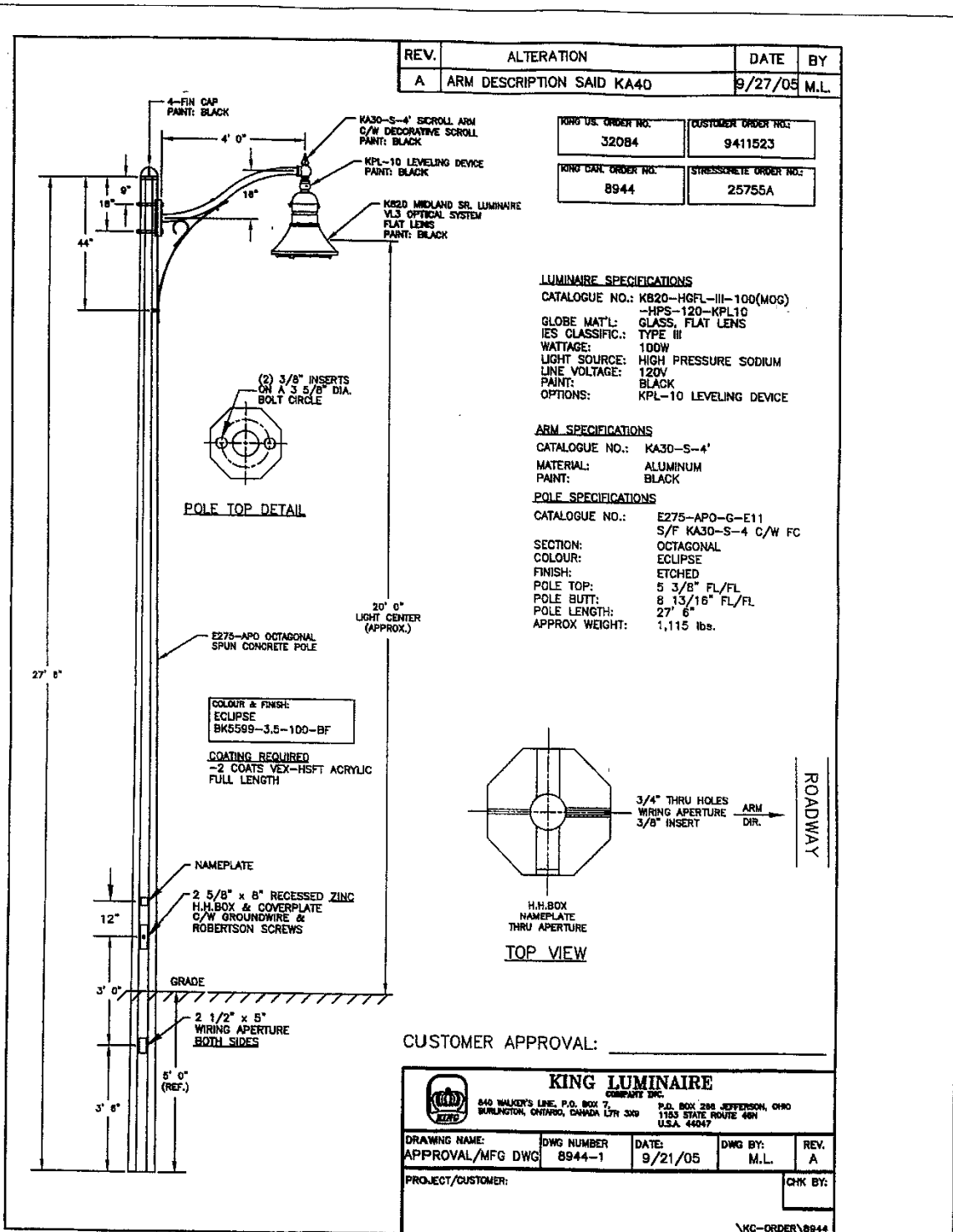

The Blue Mountains
 Street Lighting Standard Style A

Date March 2009	Scale N.T.S.	Dwg No. LT-STD-A-POLE
--------------------	-----------------	--------------------------

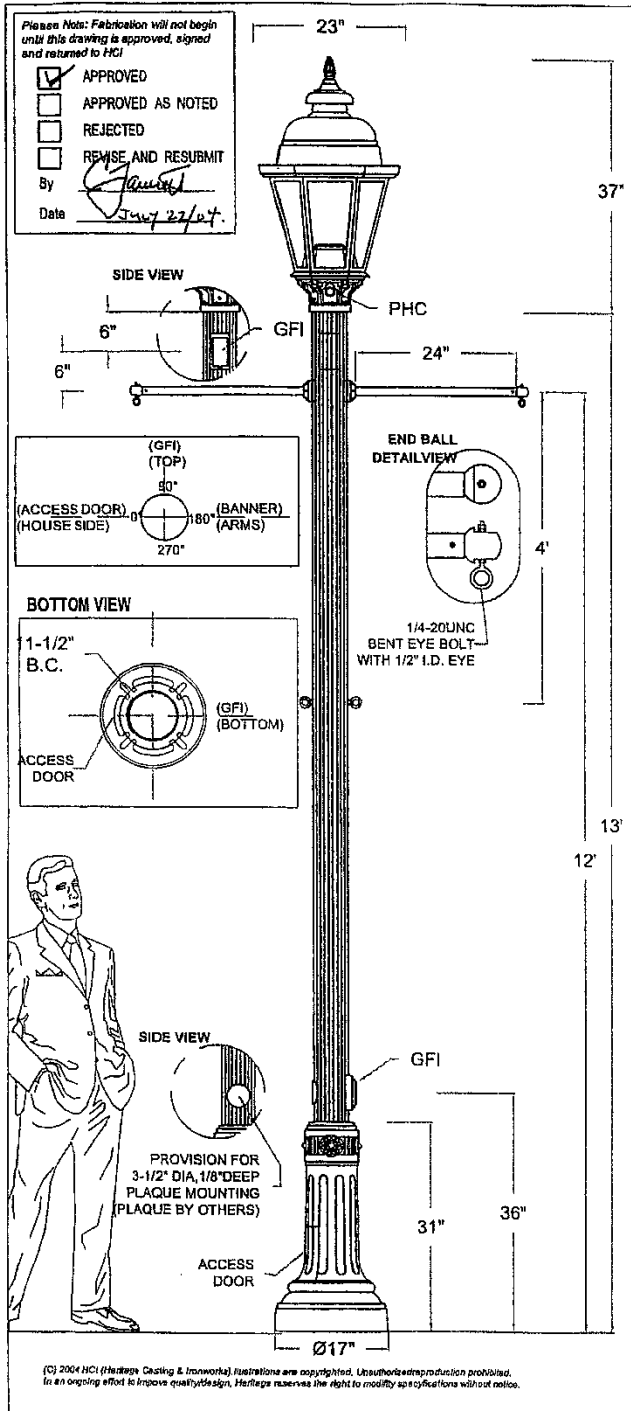

Approval Drawing
Light Standard: F146-L-MOD-P452-5FC

Diffuser Type: Clear.
Diffuser Material: Tempered glass.
Optical System: Roadway type multi faceted, highly polished cutoff reflector.
Light distribution: IES Type III
Luminaire Housing Material: Cast and spun aluminum.
Hood: Hinged for easy access to lamp and ballast.
Ballast: HPS high power factor mounted on removable plate. A quick disconnect wiring system allows for fast easy ballast maintenance.
 Wattage - 150W
 Voltage - 120V
 Socket - Mogul (4KV).
Photocontrol: Luminaire intergrated button type photocell 120V.
Receptacles: Duplex GFI top and bottom orientation (SEE DETAIL)
Pole: Extruded fluted aluminum .250(6mm) thick with 12 flutes.
Base Cover: One-piece cast aluminum permanently welded to pole
Anchor Bolts: 4 galvanized 19mm (3/4") x 610mm (24") long. Bolt Circle 11-1/2"
Banner Arms: Made out of 1-1/4" round steel tubing with 2" dia cast aluminum ball drilled 1/4"DIA with eye bolt. (20lbs max. loading)
Finish: Electrostatically applied, thermoset polyester powder-coat finish with XL4 four part corrosion inhibiting process.
Colour: Black RAL # 9011

Date: JUL.21,2004 Drawing No: 4354A-1
 Model: F146-L-MOD-CTG-150HPS-120V-SR-3-PCB-P452-5FC-13-GFI(TOP)-GFI(BOTTOM)-BA2H-BM-EB
 Project: TOWN OF THE BLUE MOUNTAINS
 Please Note: Fabrication will not begin until this drawing is approved, signed and returned to HCI

HCI
Heritage Casting & Ironworks
 1280 Fewster Drive, Mississauga, Ontario, Canada L4W 1A4
 Tel: (905) 238-2648 Fax: (905) 238-9060
 Toll Free Canada & USA 1-800-267-3175
 E: sales@hclighting.com WEB: www.hclighting.com

The Blue Mountains		
Street Lighting Standard Style B		
Date	Scale	Dwg No.
March 2009	N.T.S.	LT-STD-B-POLE

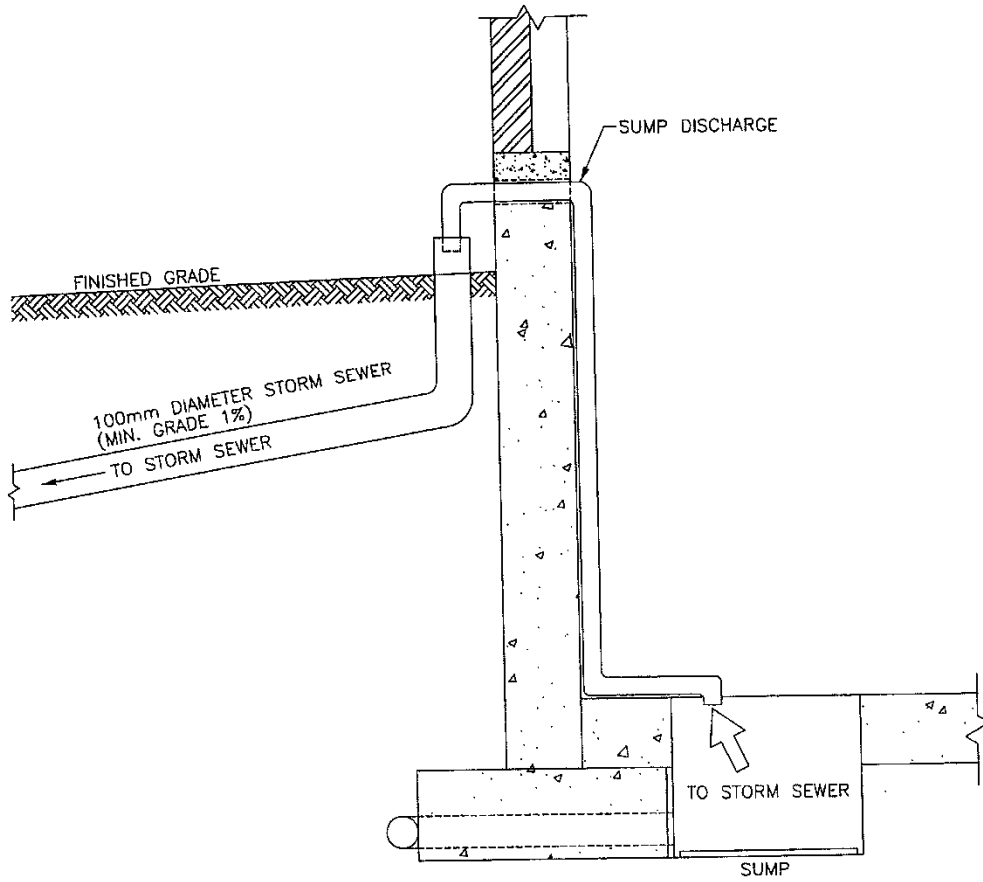

NOTES:

1. PIPE SHALL BE 100mm DIA. PVC SDR28 WHITE SEWER PIPE.
2. MIN. SLOPE OF PIPE TO BE 1 %.
3. JUNCTION OF SUMP DISCHARGE AND STORM SERVICE MUST BE 100mm ABOVE FINISHED GRADE AND IS NOT TO BE SEALED.
4. SUMP DISCHARGE PIPE TO BE CONNECTED TO THE SUMP PUMP AND FASTENED AS PER PART 7 OF THE ONTARIO BUILDING CODE.

The Blue Mountains			
Residential Storm Sewer Connection (100mm)			
Date	March 2009	Scale	N.T.S.
		Dwg No.	ST-STD-SUMP